

0.1 ~ 1.25R 1.5 ~ 2R 3R

- 고경도강 (HRC50~72)의 고정밀 ($\pm 5\mu\text{m}$) 정삭가공용 엔드밀
- 고함량의 PCBN을 적용하여 장시간 가공이 가능합니다.
- 날부인선의 조도가 뛰어나 경면가공에 적합합니다.
- 다양한 유효장을 적용함으로써 최상의 작업이 가능합니다.
- 오일미스트 사용을 권장하며, RPM 2만~5만 범위의 고속가공을 추천합니다.
- **PCBN ENDMILL for precise finishing ($\pm 5\mu\text{m}$) of hardened steel (HRC50~72)**
- Long tool life by high content PCBN.
- Excellent surface finish.
- Various flute length for optimum performance.
- Recommend high speed (20,000~50,000RPM) with oil-mist.
- C.B.N (Cubic Boron Nitride)

D Size	D Tolerance
$\varnothing 0.2 \sim 6$	+0 ~ -0.01mm

단위 : mm

Order Number	날경 Diameter R x D	날장 Length of cut L1	유효장 Effective Length L2	전장 Overall Length L	샙크 Shank Dia d	비고	Order Number	날경 Diameter R x D	날장 Length of cut L1	유효장 Effective Length L2	전장 Overall Length L	샙크 Shank Dia d	비고
2BCBN 002 002 S04	0.1R X 0.2	0.2	-	48	4		2BCBN 015 040 S04	0.75R X 1.5	1	4	48	4	
2BCBN 002 004 S04	0.1R X 0.2	0.4	-	48	4		2BCBN 015 060 S04	0.75R X 1.5	1	6	48	4	
2BCBN 003 003 S04	0.15R X 0.3	0.3	-	48	4		2BCBN 015 080 S04	0.75R X 1.5	1	8	48	4	
2BCBN 003 005 S04	0.15R X 0.3	0.5	-	48	4		2BCBN 015 100 S04	0.75R X 1.5	1	10	48	4	
2BCBN 004 015 S04	0.2R X 0.4	0.3	1.5	48	4		2BCBN 015 120 S04	0.75R X 1.5	1	12	48	4	
2BCBN 004 020 S04	0.2R X 0.4	0.3	2	48	4		2BCBN 015 140 S04	0.75R X 1.5	1	14	48	4	
2BCBN 004 030 S04	0.2R X 0.4	0.3	3	48	4		2BCBN 015 160 S04	0.75R X 1.5	1	16	48	4	
2BCBN 004 040 S04	0.2R X 0.4	0.3	4	48	4		2BCBN 015 180 S04	0.75R X 1.5	1	18	48	4	
2BCBN 004 050 S04	0.2R X 0.4	0.3	5	48	4		2BCBN 020 040 S04	1R X 2	1.2	4	50	4	
2BCBN 004 060 S04	0.2R X 0.4	0.3	6	48	4		2BCBN 020 060 S04	1R X 2	1.2	6	50	4	
2BCBN 005 015 S04	0.25R X 0.5	0.4	1.5	48	4		2BCBN 020 080 S04	1R X 2	1.2	8	50	4	
2BCBN 005 020 S04	0.25R X 0.5	0.4	2	48	4		2BCBN 020 100 S04	1R X 2	1.2	10	50	4	
2BCBN 005 030 S04	0.25R X 0.5	0.4	3	48	4		2BCBN 020 120 S04	1R X 2	1.2	12	50	4	
2BCBN 005 040 S04	0.25R X 0.5	0.4	4	48	4		2BCBN 020 140 S04	1R X 2	1.2	14	50	4	
2BCBN 005 050 S04	0.25R X 0.5	0.4	5	48	4		2BCBN 020 160 S04	1R X 2	1.2	16	50	4	
2BCBN 005 060 S04	0.25R X 0.5	0.4	6	48	4		2BCBN 020 180 S04	1R X 2	1.2	18	50	4	
2BCBN 005 080 S04	0.25R X 0.5	0.4	8	48	4		2BCBN 025 060 S06	1.25R X 2.5	1.6	6	66	6	
2BCBN 006 015 S04	0.3R X 0.6	0.5	1.5	48	4		2BCBN 025 100 S06	1.25R X 2.5	1.6	10	66	6	
2BCBN 006 020 S04	0.3R X 0.6	0.5	2	48	4		2BCBN 025 160 S06	1.25R X 2.5	1.6	16	66	6	
2BCBN 006 030 S04	0.3R X 0.6	0.5	3	48	4		2BCBN 025 200 S06	1.25R X 2.5	1.6	20	66	6	
2BCBN 006 040 S04	0.3R X 0.6	0.5	4	48	4		2BCBN 030 060 S06	1.5R X 3	1.8	6	66	6	
2BCBN 006 050 S04	0.3R X 0.6	0.5	5	48	4		2BCBN 030 080 S06	1.5R X 3	1.8	8	66	6	
2BCBN 006 060 S04	0.3R X 0.6	0.5	6	48	4		2BCBN 030 100 S06	1.5R X 3	1.8	10	66	6	
2BCBN 006 080 S04	0.3R X 0.6	0.5	8	48	4		2BCBN 030 120 S06	1.5R X 3	1.8	12	66	6	
2BCBN 006 100 S04	0.3R X 0.6	0.5	10	48	4		2BCBN 030 160 S06	1.5R X 3	1.8	16	66	6	
2BCBN 007 020 S04	0.35R X 0.7	0.5	2	48	4		2BCBN 030 200 S06	1.5R X 3	1.8	20	66	6	
2BCBN 007 040 S04	0.35R X 0.7	0.5	4	48	4		2BCBN 040 060 S06	2R X 4	2.4	6	66	6	
2BCBN 008 020 S04	0.4R X 0.8	0.6	2	48	4		2BCBN 040 080 S06	2R X 4	2.4	8	66	6	
2BCBN 008 040 S04	0.4R X 0.8	0.6	4	48	4		2BCBN 040 100 S06	2R X 4	2.4	10	66	6	
2BCBN 008 060 S04	0.4R X 0.8	0.6	6	48	4		2BCBN 040 120 S06	2R X 4	2.4	12	66	6	
2BCBN 008 080 S04	0.4R X 0.8	0.6	8	48	4		2BCBN 040 160 S06	2R X 4	2.4	16	66	6	
2BCBN 008 100 S04	0.4R X 0.8	0.6	10	48	4		2BCBN 040 200 S06	2R X 4	2.4	20	66	6	
2BCBN 009 020 S04	0.45R X 0.9	0.6	2	48	4		2BCBN 060 035 S06	3R X 6	3.5	-	83	6	
2BCBN 009 040 S04	0.45R X 0.9	0.6	4	48	4		2BCBN 060 100 S06	3R X 6	3.5	10	83	6	
2BCBN 010 025 S04	0.5R X 1	0.7	2.5	48	4		2BCBN 060 200 S06	3R X 6	3.5	20	83	6	
2BCBN 010 040 S04	0.5R X 1	0.7	4	48	4								
2BCBN 010 050 S04	0.5R X 1	0.7	5	48	4								
2BCBN 010 060 S04	0.5R X 1	0.7	6	48	4								
2BCBN 010 080 S04	0.5R X 1	0.7	8	48	4								
2BCBN 010 100 S04	0.5R X 1	0.7	10	48	4								
2BCBN 010 120 S04	0.5R X 1	0.7	12	48	4								
2BCBN 010 160 S04	0.5R X 1	0.7	16	48	4								
2BCBN 012 040 S04	0.6R X 1.2	0.8	4	48	4								
2BCBN 012 060 S04	0.6R X 1.2	0.8	6	48	4								
2BCBN 012 080 S04	0.6R X 1.2	0.8	8	48	4								
2BCBN 012 100 S04	0.6R X 1.2	0.8	10	48	4								
2BCBN 012 120 S04	0.6R X 1.2	0.8	12	48	4								
2BCBN 012 160 S04	0.6R X 1.2	0.8	16	48	4								

2날CBN 고속가공용 직선날 리브 볼 엔드밀

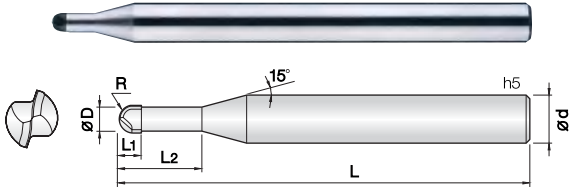

- 고경도강(HRc50~72)의 고정밀(±5μm) 정삭가공용 엔드밀
- 고함량의 PCBN을 적용하여 장시간 가공이 가능합니다.
- 날부 스트레이트 타입 형상으로 치핑을 더욱 최소화 하였습니다.
- 날부인선의 조도가 뛰어나 경면가공에 적합합니다.
- 다양한 유효장을 적용함으로써 최상의 작업이 가능합니다.
- 오일미스트 사용을 권장하며, RPM 2만~5만 범위의 고속가공을 추천합니다.
- **PCBN ENDMILL for precise finishing(±5 μm) of hardened steel (HRc50~72)**
- Long tool life by high content PCBN.
- Straight type Design for Minimizing edge chipping.
- Excellent surface finish.
- Various flute length for optimum performance.
- Recommend high speed(20,000~50,000RPM) with oil-mist.
- C.B.N (Cubic Boron Nitride)

2

CBN

R

R

R

0°

±0.005
±0.007
±0.01
Helix Angle

0.1 ~ 1.25R
1.5 ~ 2R
3R

D Size	D Tolerance
ø0.2 ~ 6	+0 ~ -0.01mm

단위 : mm

Order Number	날경 Diameter R × D	날장 Length of cut L1	유효장 Effective Length L2	전장 Overall Length L	샙크 Shank Dia d	비고					
2SBCBN 002 002 S04	0.1R X 0.2	0.2	-	48	4						
2SBCBN 002 004 S04	0.1R X 0.2	0.4	-	48	4						
2SBCBN 003 003 S04	0.15R X 0.3	0.3	-	48	4						
2SBCBN 003 005 S04	0.15R X 0.3	0.5	-	48	4						
2SBCBN 004 015 S04	0.2R X 0.4	0.3	1.5	48	4						
2SBCBN 005 015 S04	0.25R X 0.5	0.4	1.5	48	4						
2SBCBN 005 020 S04	0.25R X 0.5	0.4	2	48	4						
2SBCBN 006 015 S04	0.3R X 0.6	0.5	1.5	48	4						
2SBCBN 006 020 S04	0.3R X 0.6	0.5	2	48	4						
2SBCBN 006 030 S04	0.3R X 0.6	0.5	3	48	4						
2SBCBN 006 040 S04	0.3R X 0.6	0.5	4	48	4						
2SBCBN 007 020 S04	0.35R X 0.7	0.5	2	48	4						
2SBCBN 008 020 S04	0.4R X 0.8	0.6	2	48	4						
2SBCBN 008 030 S04	0.4R X 0.8	0.6	3	48	4						
2SBCBN 008 040 S04	0.4R X 0.8	0.6	4	48	4						
2SBCBN 009 020 S04	0.45R X 0.9	0.6	2	48	4						
2SBCBN 010 025 S04	0.5R X 1	0.7	2.5	48	4						
2SBCBN 010 040 S04	0.5R X 1	0.7	4	48	4						
2SBCBN 010 050 S04	0.5R X 1	0.7	5	48	4						
2SBCBN 010 060 S04	0.5R X 1	0.7	6	48	4						
2SBCBN 012 040 S04	0.6R X 1.2	0.8	4	48	4						
2SBCBN 015 040 S04	0.75R X 1.5	1	4	48	4						
2SBCBN 015 060 S04	0.75R X 1.5	1	6	48	4						
2SBCBN 015 080 S04	0.75R X 1.5	1	8	48	4						
2SBCBN 015 100 S04	0.75R X 1.5	1	10	48	4						
2SBCBN 020 040 S04	1R X 2	1.2	4	50	4						
2SBCBN 020 060 S04	1R X 2	1.2	6	50	4						
2SBCBN 020 080 S04	1R X 2	1.2	8	50	4						
2SBCBN 020 100 S04	1R X 2	1.2	10	50	4						
2SBCBN 020 120 S04	1R X 2	1.2	12	50	4						
2SBCBN 025 060 S06	1.25R X 2.5	1.6	6	66	6						
2SBCBN 030 060 S06	1.5R X 3	1.8	6	66	6						
2SBCBN 030 080 S06	1.5R X 3	1.8	8	66	6						
2SBCBN 030 100 S06	1.5R X 3	1.8	10	66	6						
2SBCBN 030 120 S06	1.5R X 3	1.8	12	66	6						
2SBCBN 030 160 S06	1.5R X 3	1.8	16	66	6						
2SBCBN 030 200 S06	1.5R X 3	1.8	20	66	6						
2SBCBN 040 060 S06	2R X 4	2.4	6	66	6						
2SBCBN 040 080 S06	2R X 4	2.4	8	66	6						
2SBCBN 040 100 S06	2R X 4	2.4	10	66	6						
2SBCBN 040 120 S06	2R X 4	2.4	12	66	6						
2SBCBN 040 160 S06	2R X 4	2.4	16	66	6						
2SBCBN 040 200 S06	2R X 4	2.4	20	66	6						
2SBCBN 060 035 S06	3R X 6	3.5	-	83	6						
2SBCBN 060 100 S06	3R X 6	3.5	10	83	6						

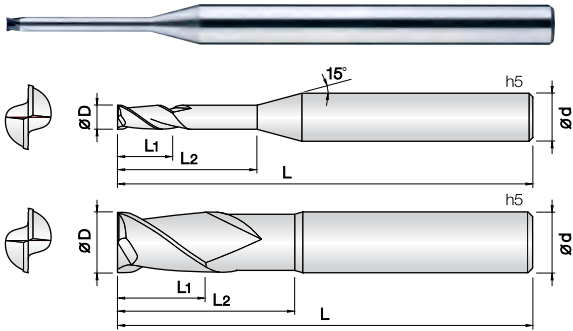

ø0.2 ~ ø6

Shield Edge

- 고경도강(HRc50~72)의 고정밀($\pm 5\mu\text{m}$) 정삭가공용 엔드밀
- 고힐량의 PCBN을 적용하여 장시간 가공이 가능합니다.
- 날부인선의 조도가 뛰어나 경면가공에 적합합니다.
- 다양한 유효장을 적용함으로써 최상의 작업이 가능합니다.
- 오일미스트 사용을 권장하며, RPM 2만~5만 범위의 고속가공을 추천합니다.
- **PCBN ENDMILL for precise finishing($\pm 5\mu\text{m}$) of hardened steel (HRc50~72)**
- Long tool life by high content PCBN.
- Excellent surface finish.
- Various flute length for optimum performance.
- Recommend high speed(20,000~50,000RPM) with oil-mist.
- C.B.N (Cubic Boron Nitride)

D Size	D Tolerance
ø0.2 ~ 6	+0 ~ -0.01mm

단위 : mm

Order Number	날경 Diameter D	날장 Length of cut L1	유효장 Effective Length L2	전장 Overall Length L	샙크 Shank Dia d	비고	Order Number	날경 Diameter D	날장 Length of cut L1	유효장 Effective Length L2	전장 Overall Length L	샙크 Shank Dia d	비고
2ECBN 002 002 S04	0.2	0.2	-	48	4		2ECBN 012 060 S04	1.2	0.7	6	48	4	
2ECBN 002 004 S04	0.2	0.4	-	48	4		2ECBN 012 080 S04	1.2	0.7	8	48	4	
2ECBN 003 003 S04	0.3	0.3	-	48	4		2ECBN 012 100 S04	1.2	0.7	10	48	4	
2ECBN 003 005 S04	0.3	0.5	-	48	4		2ECBN 012 120 S04	1.2	0.7	12	48	4	
2ECBN 004 015 S04	0.4	0.3	1.5	48	4		2ECBN 012 160 S04	1.2	0.7	16	48	4	
2ECBN 004 020 S04	0.4	0.3	2	48	4		2ECBN 015 030 S04	1.5	0.8	3	48	4	
2ECBN 004 030 S04	0.4	0.3	3	48	4		2ECBN 015 060 S04	1.5	0.8	6	48	4	
2ECBN 004 040 S04	0.4	0.3	4	48	4		2ECBN 015 080 S04	1.5	0.8	8	48	4	
2ECBN 004 050 S04	0.4	0.3	5	48	4		2ECBN 015 100 S04	1.5	0.8	10	48	4	
2ECBN 004 060 S04	0.4	0.3	6	48	4		2ECBN 015 120 S04	1.5	0.8	12	48	4	
2ECBN 005 015 S04	0.5	0.4	1.5	48	4		2ECBN 015 140 S04	1.5	0.8	14	48	4	
2ECBN 005 020 S04	0.5	0.4	2	48	4		2ECBN 015 160 S04	1.5	0.8	16	48	4	
2ECBN 005 030 S04	0.5	0.4	3	48	4		2ECBN 015 180 S04	1.5	0.8	18	48	4	
2ECBN 005 040 S04	0.5	0.4	4	48	4		2ECBN 020 030 S04	2	0.9	3	50	4	
2ECBN 005 050 S04	0.5	0.4	5	48	4		2ECBN 020 060 S04	2	0.9	6	50	4	
2ECBN 005 060 S04	0.5	0.4	6	48	4		2ECBN 020 080 S04	2	0.9	8	50	4	
2ECBN 005 080 S04	0.5	0.4	8	48	4		2ECBN 020 100 S04	2	0.9	10	50	4	
2ECBN 006 015 S04	0.6	0.5	1.5	48	4		2ECBN 020 120 S04	2	0.9	12	50	4	
2ECBN 006 020 S04	0.6	0.5	2	48	4		2ECBN 020 140 S04	2	0.9	14	50	4	
2ECBN 006 030 S04	0.6	0.5	3	48	4		2ECBN 020 160 S04	2	0.9	16	50	4	
2ECBN 006 040 S04	0.6	0.5	4	48	4		2ECBN 020 180 S04	2	0.9	18	50	4	
2ECBN 006 060 S04	0.6	0.5	6	48	4		2ECBN 025 060 S06	2.5	1.2	6	66	6	
2ECBN 006 080 S04	0.6	0.5	8	48	4		2ECBN 025 100 S06	2.5	1.2	10	66	6	
2ECBN 006 100 S04	0.6	0.5	10	48	4		2ECBN 025 160 S06	2.5	1.2	16	66	6	
2ECBN 007 025 S04	0.7	0.5	2.5	48	4		2ECBN 025 200 S06	2.5	1.2	20	66	6	
2ECBN 007 040 S04	0.7	0.5	4	48	4		2ECBN 030 060 S06	3	1.2	6	66	6	
2ECBN 007 060 S04	0.7	0.5	6	48	4		2ECBN 030 080 S06	3	1.2	8	66	6	
2ECBN 008 025 S04	0.8	0.6	2.5	48	4		2ECBN 030 100 S06	3	1.2	10	66	6	
2ECBN 008 040 S04	0.8	0.6	4	48	4		2ECBN 030 120 S06	3	1.2	12	66	6	
2ECBN 008 060 S04	0.8	0.6	6	48	4		2ECBN 030 160 S06	3	1.2	16	66	6	
2ECBN 008 080 S04	0.8	0.6	8	48	4		2ECBN 030 200 S06	3	1.2	20	66	6	
2ECBN 008 100 S04	0.8	0.6	10	48	4		2ECBN 040 060 S06	4	1.5	6	66	6	
2ECBN 009 025 S04	0.9	0.6	2.5	48	4		2ECBN 040 080 S06	4	1.5	8	66	6	
2ECBN 009 040 S04	0.9	0.6	4	48	4		2ECBN 040 100 S06	4	1.5	10	66	6	
2ECBN 009 060 S04	0.9	0.6	6	48	4		2ECBN 040 120 S06	4	1.5	12	66	6	
2ECBN 009 080 S04	0.9	0.6	8	48	4		2ECBN 040 160 S06	4	1.5	16	66	6	
2ECBN 009 100 S04	0.9	0.6	10	48	4		2ECBN 040 200 S06	4	1.5	20	66	6	
2ECBN 010 025 S04	1	0.7	2.5	48	4		2ECBN 060 030 S06	6	3	-	83	6	
2ECBN 010 040 S04	1	0.7	4	48	4		2ECBN 060 100 S06	6	3	10	83	6	
2ECBN 010 050 S04	1	0.7	5	48	4		2ECBN 060 200 S06	6	3	20	83	6	
2ECBN 010 060 S04	1	0.7	6	48	4								
2ECBN 010 080 S04	1	0.7	8	48	4								
2ECBN 010 100 S04	1	0.7	10	48	4								
2ECBN 010 120 S04	1	0.7	12	48	4								
2ECBN 010 140 S04	1	0.7	14	48	4								
2ECBN 010 160 S04	1	0.7	16	48	4								
2ECBN 012 030 S04	1.2	0.7	3	48	4								
2ECBN 012 040 S04	1.2	0.7	4	48	4								

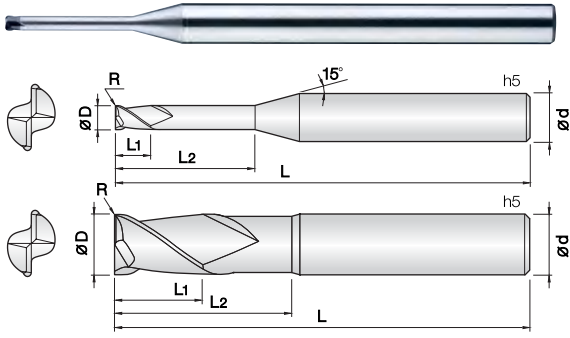

- 고경도강(HRc50~72)의 고정밀(±5µm) 정삭가공용 엔드밀
- 고함량의 PCBN을 적용하여 장시간 가공이 가능합니다.
- 날부인선의 조도가 뛰어나 경면가공에 적합합니다.
- 다양한 유효장을 적용함으로써 최상의 작업이 가능합니다.
- 오일미스트 사용을 권장하며, RPM 2만~5만 범위의 고속가공을 추천합니다.
- **PCBN ENDMILL for precise finishing(±5µm) of hardened steel (HRc50~72)**
- Long tool life by high content PCBN.
- Excellent surface finish.
- Various flute length for optimum performance.
- Recommend high speed(20,000~50,000RPM) with oil-mist.
- C.B.N (Cubic Boron Nitride)



R0.02 ~ 1

D Size	D Tolerance
Ø0.4 ~ 6	+0 ~ -0.01mm

단위 : mm

Order Number	날경 Diameter D x R	날장 Length of cut L1	유효장 Effective Length L2	전장 Overall Length L	샙크 Shank Dia d	비고	Order Number	날경 Diameter D x R	날장 Length of cut L1	유효장 Effective Length L2	전장 Overall Length L	샙크 Shank Dia d	비고
2CCBN 004 0002 015	0.4 X R0.02	0.3	1.5	48	4		2CCBN 010 002 025	1 X R0.2	0.7	2.5	48	4	
2CCBN 004 0002 020	0.4 X R0.02	0.3	2	48	4		2CCBN 010 002 040	1 X R0.2	0.7	4	48	4	
2CCBN 004 0005 015	0.4 X R0.05	0.3	1.5	48	4		2CCBN 010 002 060	1 X R0.2	0.7	6	48	4	
2CCBN 004 0005 020	0.4 X R0.05	0.3	2	48	4		2CCBN 010 002 080	1 X R0.2	0.7	8	48	4	
2CCBN 004 001 015	0.4 X R0.1	0.3	1.5	48	4		2CCBN 010 002 100	1 X R0.2	0.7	10	48	4	
2CCBN 004 001 020	0.4 X R0.1	0.3	2	48	4		2CCBN 010 003 025	1 X R0.3	0.7	2.5	48	4	
2CCBN 005 0005 015	0.5 X R0.05	0.4	1.5	48	4		2CCBN 010 003 040	1 X R0.3	0.7	4	48	4	
2CCBN 005 0005 020	0.5 X R0.05	0.4	2	48	4		2CCBN 010 003 060	1 X R0.3	0.7	6	48	4	
2CCBN 005 0005 030	0.5 X R0.05	0.4	3	48	4		2CCBN 010 003 080	1 X R0.3	0.7	8	48	4	
2CCBN 005 0005 040	0.5 X R0.05	0.4	4	48	4		2CCBN 010 003 100	1 X R0.3	0.7	10	48	4	
2CCBN 005 0005 050	0.5 X R0.05	0.4	5	48	4		2CCBN 012 001 030	1.2 X R0.1	0.7	3	48	4	
2CCBN 005 001 015	0.5 X R0.1	0.4	1.5	48	4		2CCBN 012 001 040	1.2 X R0.1	0.7	4	48	4	
2CCBN 005 001 020	0.5 X R0.1	0.4	2	48	4		2CCBN 012 001 060	1.2 X R0.1	0.7	6	48	4	
2CCBN 005 001 030	0.5 X R0.1	0.4	3	48	4		2CCBN 012 001 080	1.2 X R0.1	0.7	8	48	4	
2CCBN 005 001 040	0.5 X R0.1	0.4	4	48	4		2CCBN 012 001 100	1.2 X R0.1	0.7	10	48	4	
2CCBN 005 001 050	0.5 X R0.1	0.4	5	48	4		2CCBN 012 002 030	1.2 X R0.2	0.7	3	48	4	
2CCBN 006 0005 020	0.6 X R0.05	0.5	2	48	4		2CCBN 012 002 040	1.2 X R0.2	0.7	4	48	4	
2CCBN 006 0005 030	0.6 X R0.05	0.5	3	48	4		2CCBN 012 002 060	1.2 X R0.2	0.7	6	48	4	
2CCBN 006 0005 040	0.6 X R0.05	0.5	4	48	4		2CCBN 012 002 080	1.2 X R0.2	0.7	8	48	4	
2CCBN 006 0005 060	0.6 X R0.05	0.5	6	48	4		2CCBN 012 002 100	1.2 X R0.2	0.7	10	48	4	
2CCBN 006 001 020	0.6 X R0.1	0.5	2	48	4		2CCBN 012 003 030	1.2 X R0.3	0.7	3	48	4	
2CCBN 006 001 030	0.6 X R0.1	0.5	3	48	4		2CCBN 012 003 040	1.2 X R0.3	0.7	4	48	4	
2CCBN 006 001 040	0.6 X R0.1	0.5	4	48	4		2CCBN 012 003 060	1.2 X R0.3	0.7	6	48	4	
2CCBN 006 001 060	0.6 X R0.1	0.5	6	48	4		2CCBN 012 003 080	1.2 X R0.3	0.7	8	48	4	
2CCBN 007 001 025	0.7 X R0.1	0.5	2.5	48	4		2CCBN 012 003 100	1.2 X R0.3	0.7	10	48	4	
2CCBN 007 001 040	0.7 X R0.1	0.5	4	48	4		2CCBN 015 0002 030	1.5 X R0.02	0.8	3	48	4	
2CCBN 007 001 060	0.7 X R0.1	0.5	6	48	4		2CCBN 015 0002 040	1.5 X R0.02	0.8	4	48	4	
2CCBN 008 001 025	0.8 X R0.1	0.6	2.5	48	4		2CCBN 015 0002 060	1.5 X R0.02	0.8	6	48	4	
2CCBN 008 001 040	0.8 X R0.1	0.6	4	48	4		2CCBN 015 0002 080	1.5 X R0.02	0.8	8	48	4	
2CCBN 008 001 060	0.8 X R0.1	0.6	6	48	4		2CCBN 015 0002 100	1.5 X R0.02	0.8	10	48	4	
2CCBN 008 002 025	0.8 X R0.2	0.6	2.5	48	4		2CCBN 015 0005 030	1.5 X R0.05	0.8	3	48	4	
2CCBN 008 002 040	0.8 X R0.2	0.6	4	48	4		2CCBN 015 0005 040	1.5 X R0.05	0.8	4	48	4	
2CCBN 008 002 060	0.8 X R0.2	0.6	6	48	4		2CCBN 015 0005 060	1.5 X R0.05	0.8	6	48	4	
2CCBN 010 0002 025	1 X R0.02	0.7	2.5	48	4		2CCBN 015 0005 080	1.5 X R0.05	0.8	8	48	4	
2CCBN 010 0002 040	1 X R0.02	0.7	4	48	4		2CCBN 015 0005 100	1.5 X R0.05	0.8	10	48	4	
2CCBN 010 0002 060	1 X R0.02	0.7	6	48	4		2CCBN 015 001 030	1.5 X R0.1	0.8	3	48	4	
2CCBN 010 0002 080	1 X R0.02	0.7	8	48	4		2CCBN 015 001 040	1.5 X R0.1	0.8	4	48	4	
2CCBN 010 0002 100	1 X R0.02	0.7	10	48	4		2CCBN 015 001 060	1.5 X R0.1	0.8	6	48	4	
2CCBN 010 0005 025	1 X R0.05	0.7	2.5	48	4		2CCBN 015 001 080	1.5 X R0.1	0.8	8	48	4	
2CCBN 010 0005 040	1 X R0.05	0.7	4	48	4		2CCBN 015 001 100	1.5 X R0.1	0.8	10	48	4	
2CCBN 010 0005 060	1 X R0.05	0.7	6	48	4		2CCBN 015 002 030	1.5 X R0.2	0.8	3	48	4	
2CCBN 010 0005 080	1 X R0.05	0.7	8	48	4		2CCBN 015 002 040	1.5 X R0.2	0.8	4	48	4	
2CCBN 010 0005 100	1 X R0.05	0.7	10	48	4		2CCBN 015 002 060	1.5 X R0.2	0.8	6	48	4	
2CCBN 010 001 025	1 X R0.1	0.7	2.5	48	4		2CCBN 015 002 080	1.5 X R0.2	0.8	8	48	4	
2CCBN 010 001 040	1 X R0.1	0.7	4	48	4		2CCBN 015 002 100	1.5 X R0.2	0.8	10	48	4	
2CCBN 010 001 060	1 X R0.1	0.7	6	48	4		2CCBN 015 003 030	1.5 X R0.3	0.8	3	48	4	
2CCBN 010 001 080	1 X R0.1	0.7	8	48	4		2CCBN 015 003 040	1.5 X R0.3	0.8	4	48	4	
2CCBN 010 001 100	1 X R0.1	0.7	10	48	4		2CCBN 015 003 060	1.5 X R0.3	0.8	6	48	4	

단위 : mm

Order Number	날경 D×R	날장 Length of cut L1	유효장 Effective Length L2	전장 Overall Length L	샙크 Shank Dia d	비고	Order Number	날경 D×R	날장 Length of cut L1	유효장 Effective Length L2	전장 Overall Length L	샙크 Shank Dia d	비고
2CCBN 015 003 080	1.5 X R0.3	0.8	8	48	4		2CCBN 040 005 100	4 X R0.5	1.5	10	66	6	
2CCBN 015 003 100	1.5 X R0.3	0.8	10	48	4		2CCBN 040 005 160	4 X R0.5	1.5	16	66	6	
2CCBN 020 0002 030	2 X R0.02	0.9	3	50	4		2CCBN 040 010 060	4 X R1	1.5	6	66	6	
2CCBN 020 0002 060	2 X R0.02	0.9	6	50	4		2CCBN 040 010 100	4 X R1	1.5	10	66	6	
2CCBN 020 0002 080	2 X R0.02	0.9	8	50	4		2CCBN 040 010 160	4 X R1	1.5	16	66	6	
2CCBN 020 0002 100	2 X R0.02	0.9	10	50	4		2CCBN 060 003 030	6 X R0.3	3	-	83	6	
2CCBN 020 0005 030	2 X R0.05	0.9	3	50	4		2CCBN 060 003 150	6 X R0.3	3	15	83	6	
2CCBN 020 0005 060	2 X R0.05	0.9	6	50	4		2CCBN 060 005 030	6 X R0.5	3	-	83	6	
2CCBN 020 0005 080	2 X R0.05	0.9	8	50	4		2CCBN 060 005 150	6 X R0.5	3	15	83	6	
2CCBN 020 0005 100	2 X R0.05	0.9	10	50	4		2CCBN 060 010 030	6 X R1	3	-	83	6	
2CCBN 020 001 030	2 X R0.1	0.9	3	50	4		2CCBN 060 010 150	6 X R1	3	15	83	6	
2CCBN 020 001 060	2 X R0.1	0.9	6	50	4								
2CCBN 020 001 080	2 X R0.1	0.9	8	50	4								
2CCBN 020 001 100	2 X R0.1	0.9	10	50	4								
2CCBN 020 002 030	2 X R0.2	0.9	3	50	4								
2CCBN 020 002 060	2 X R0.2	0.9	6	50	4								
2CCBN 020 002 080	2 X R0.2	0.9	8	50	4								
2CCBN 020 002 100	2 X R0.2	0.9	10	50	4								
2CCBN 020 003 030	2 X R0.3	0.9	3	50	4								
2CCBN 020 003 060	2 X R0.3	0.9	6	50	4								
2CCBN 020 003 080	2 X R0.3	0.9	8	50	4								
2CCBN 020 003 100	2 X R0.3	0.9	10	50	4								
2CCBN 020 005 030	2 X R0.5	0.9	3	50	4								
2CCBN 020 005 060	2 X R0.5	0.9	6	50	4								
2CCBN 020 005 080	2 X R0.5	0.9	8	50	4								
2CCBN 020 005 100	2 X R0.5	0.9	10	50	4								
2CCBN 025 001 060	2.5 X R0.1	1.2	6	66	6								
2CCBN 025 001 100	2.5 X R0.1	1.2	10	66	6								
2CCBN 025 002 060	2.5 X R0.2	1.2	6	66	6								
2CCBN 025 002 100	2.5 X R0.2	1.2	10	66	6								
2CCBN 025 003 060	2.5 X R0.3	1.2	6	66	6								
2CCBN 025 003 100	2.5 X R0.3	1.2	10	66	6								
2CCBN 030 001 060	3 X R0.1	1.2	6	66	6								
2CCBN 030 001 100	3 X R0.1	1.2	10	66	6								
2CCBN 030 001 160	3 X R0.1	1.2	16	66	6								
2CCBN 030 001 200	3 X R0.1	1.2	20	66	6								
2CCBN 030 002 060	3 X R0.2	1.2	6	66	6								
2CCBN 030 002 100	3 X R0.2	1.2	10	66	6								
2CCBN 030 002 160	3 X R0.2	1.2	16	66	6								
2CCBN 030 002 200	3 X R0.2	1.2	20	66	6								
2CCBN 030 003 060	3 X R0.3	1.2	6	66	6								
2CCBN 030 003 100	3 X R0.3	1.2	10	66	6								
2CCBN 030 003 160	3 X R0.3	1.2	16	66	6								
2CCBN 030 003 200	3 X R0.3	1.2	20	66	6								
2CCBN 030 005 060	3 X R0.5	1.2	6	66	6								
2CCBN 030 005 100	3 X R0.5	1.2	10	66	6								
2CCBN 030 005 160	3 X R0.5	1.2	16	66	6								
2CCBN 030 005 200	3 X R0.5	1.2	20	66	6								
2CCBN 030 010 060	3 X R1	1.2	6	66	6								
2CCBN 030 010 100	3 X R1	1.2	10	66	6								
2CCBN 030 010 160	3 X R1	1.2	16	66	6								
2CCBN 030 010 200	3 X R1	1.2	20	66	6								
2CCBN 040 001 060	4 X R0.1	1.5	6	66	6								
2CCBN 040 001 100	4 X R0.1	1.5	10	66	6								
2CCBN 040 001 160	4 X R0.1	1.5	16	66	6								
2CCBN 040 002 060	4 X R0.2	1.5	6	66	6								
2CCBN 040 002 100	4 X R0.2	1.5	10	66	6								
2CCBN 040 002 160	4 X R0.2	1.5	16	66	6								
2CCBN 040 003 060	4 X R0.3	1.5	6	66	6								
2CCBN 040 003 100	4 X R0.3	1.5	10	66	6								
2CCBN 040 003 160	4 X R0.3	1.5	16	66	6								
2CCBN 040 005 060	4 X R0.5	1.5	6	66	6								

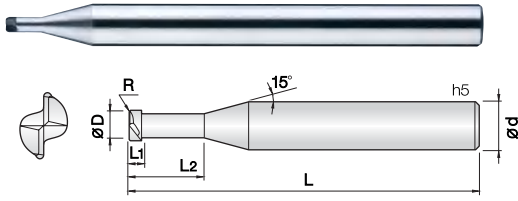

- 고경도강(HRc50~72)의 고정밀(±5μm) 정삭가공용 엔드밀
- 고풍량의 PCBN을 적용하여 장시간 가공이 가능합니다.
- 날부 스트레이트 타입 형상으로 치핑을 더욱 최소화 하였습니다.
- 날부인선의 조도가 뛰어나 경면가공에 적합합니다.
- 다양한 유효장을 적용함으로써 최상의 작업이 가능합니다.
- 오일미스트 사용을 권장하며, RPM 2만~5만 범위의 고속가공을 추천합니다.
- **PCBN ENDMILL for precise finishing(±5μm) of hardened steel (HRc50~72)**
- Long tool life by high content PCBN.
- Straight type Design for Minimizing edge chipping.
- Excellent surface finish.
- Various flute length for optimum performance.
- Recommend high speed(20,000~50,000RPM) with oil-mist.
- C.B.N (Cubic Boron Nitride)



R0.02 ~ 1

D Size	D Tolerance
ø0.4 ~ 6	+0 ~ -0.01mm

단위 : mm

Order Number	날경 Diameter D x R	날장 Length of cut L1	유효장 Effective Length L2	전장 Overall Length L	샙크 Shank Dia d	비고	Order Number	날경 Diameter D x R	날장 Length of cut L1	유효장 Effective Length L2	전장 Overall Length L	샙크 Shank Dia d	비고
2SCCBN 004 0002 015	0.4 X R0.02	0.3	1.5	48	4		2SCCBN 030 002 060	3 X R0.2	1.2	6	66	6	
2SCCBN 004 0005 015	0.4 X R0.05	0.3	1.5	48	4		2SCCBN 030 002 100	3 X R0.2	1.2	10	66	6	
2SCCBN 004 001 015	0.4 X R0.1	0.3	1.5	48	4		2SCCBN 030 003 060	3 X R0.3	1.2	6	66	6	
2SCCBN 005 0005 015	0.5 X R0.05	0.4	1.5	48	4		2SCCBN 030 003 100	3 X R0.3	1.2	10	66	6	
2SCCBN 005 001 015	0.5 X R0.1	0.4	1.5	48	4		2SCCBN 030 005 060	3 X R0.5	1.2	6	66	6	
2SCCBN 006 0005 020	0.6 X R0.05	0.5	2	48	4		2SCCBN 030 005 100	3 X R0.5	1.2	10	66	6	
2SCCBN 006 001 020	0.6 X R0.1	0.5	2	48	4		2SCCBN 030 005 160	3 X R0.5	1.2	16	66	6	
2SCCBN 008 001 020	0.8 X R0.1	0.6	2	48	4		2SCCBN 030 010 060	3 X R1	1.2	6	66	6	
2SCCBN 008 002 020	0.8 X R0.2	0.6	2	48	4		2SCCBN 030 010 100	3 X R1	1.2	10	66	6	
2SCCBN 010 0002 025	1 X R0.02	0.7	2.5	48	4		2SCCBN 030 010 160	3 X R1	1.2	16	66	6	
2SCCBN 010 0002 040	1 X R0.02	0.7	4	48	4		2SCCBN 040 001 060	4 X R0.1	1.5	6	66	6	
2SCCBN 010 0005 025	1 X R0.05	0.7	2.5	48	4		2SCCBN 040 001 100	4 X R0.1	1.5	10	66	6	
2SCCBN 010 0005 040	1 X R0.05	0.7	4	48	4		2SCCBN 040 001 160	4 X R0.1	1.5	16	66	6	
2SCCBN 010 001 025	1 X R0.1	0.7	2.5	48	4		2SCCBN 040 002 060	4 X R0.2	1.5	6	66	6	
2SCCBN 010 001 040	1 X R0.1	0.7	4	48	4		2SCCBN 040 002 100	4 X R0.2	1.5	10	66	6	
2SCCBN 010 002 025	1 X R0.2	0.7	2.5	48	4		2SCCBN 040 002 160	4 X R0.2	1.5	16	66	6	
2SCCBN 010 002 040	1 X R0.2	0.7	4	48	4		2SCCBN 040 003 060	4 X R0.3	1.5	6	66	6	
2SCCBN 010 003 025	1 X R0.3	0.7	2.5	48	4		2SCCBN 040 003 100	4 X R0.3	1.5	10	66	6	
2SCCBN 010 003 040	1 X R0.3	0.7	4	48	4		2SCCBN 040 003 160	4 X R0.3	1.5	16	66	6	
2SCCBN 015 0002 030	1.5 X R0.02	0.8	3	48	4		2SCCBN 040 005 060	4 X R0.5	1.5	6	66	6	
2SCCBN 015 0002 040	1.5 X R0.02	0.8	4	48	4		2SCCBN 040 005 100	4 X R0.5	1.5	10	66	6	
2SCCBN 015 0005 030	1.5 X R0.05	0.8	3	48	4		2SCCBN 040 005 160	4 X R0.5	1.5	16	66	6	
2SCCBN 015 0005 040	1.5 X R0.05	0.8	4	48	4		2SCCBN 040 010 060	4 X R1	1.5	6	66	6	
2SCCBN 015 001 030	1.5 X R0.1	0.8	3	48	4		2SCCBN 040 010 100	4 X R1	1.5	10	66	6	
2SCCBN 015 001 040	1.5 X R0.1	0.8	4	48	4		2SCCBN 040 010 160	4 X R1	1.5	16	66	6	
2SCCBN 015 002 030	1.5 X R0.2	0.8	3	48	4		2SCCBN 060 003 030	6 X R0.3	3	-	83	6	
2SCCBN 015 002 040	1.5 X R0.2	0.8	4	48	4		2SCCBN 060 003 150	6 X R0.3	3	15	83	6	
2SCCBN 015 003 030	1.5 X R0.3	0.8	3	48	4		2SCCBN 060 005 030	6 X R0.5	3	-	83	6	
2SCCBN 015 003 040	1.5 X R0.3	0.8	4	48	4		2SCCBN 060 005 150	6 X R0.5	3	15	83	6	
2SCCBN 020 0002 030	2 X R0.02	0.9	3	50	4		2SCCBN 060 010 030	6 X R1	3	-	83	6	
2SCCBN 020 0002 060	2 X R0.02	0.9	6	50	4		2SCCBN 060 010 150	6 X R1	3	15	83	6	
2SCCBN 020 0005 030	2 X R0.05	0.9	3	50	4								
2SCCBN 020 0005 060	2 X R0.05	0.9	6	50	4								
2SCCBN 020 001 030	2 X R0.1	0.9	3	50	4								
2SCCBN 020 001 060	2 X R0.1	0.9	6	50	4								
2SCCBN 020 002 030	2 X R0.2	0.9	3	50	4								
2SCCBN 020 002 060	2 X R0.2	0.9	6	50	4								
2SCCBN 020 003 030	2 X R0.3	0.9	3	50	4								
2SCCBN 020 003 060	2 X R0.3	0.9	6	50	4								
2SCCBN 020 005 030	2 X R0.5	0.9	3	50	4								
2SCCBN 020 005 060	2 X R0.5	0.9	6	50	4								
2SCCBN 025 001 060	2.5 X R0.1	1.2	6	66	6								
2SCCBN 025 002 060	2.5 X R0.2	1.2	6	66	6								
2SCCBN 025 003 060	2.5 X R0.3	1.2	6	66	6								
2SCCBN 030 001 060	3 X R0.1	1.2	6	66	6								
2SCCBN 030 001 100	3 X R0.1	1.2	10	66	6								

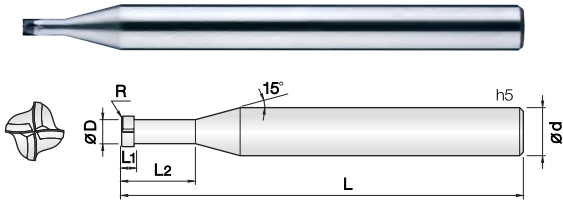

R0.1 ~ 1

- 고경도강(HRc50~72)의 고정밀($\pm 5\mu\text{m}$) 정삭가공용 엔드밀
- 고품질의 PCBN을 적용하여 장시간 가공이 가능합니다.
- 날부 스트레이트 타입 형상으로 치핑을 더욱 최소화 하였습니다.
- 날부인선의 조도가 뛰어나 경면가공에 적합합니다.
- 다양한 유효장을 적용함으로써 최상의 작업이 가능합니다.
- 오일미스트 사용을 권장하며, RPM 2만~5만 범위의 고속가공을 추천합니다.
- **PCBN ENDMILL for precise finishing($\pm 5\mu\text{m}$) of hardened steel (HRc50~72)**
- Long tool life by high content PCBN.
- Straight type Design for Minimizing edge chipping.
- Excellent surface finish.
- Various flute length for optimum performance.
- Recommend high speed(20,000~50,000RPM) with oil-mist.
- C.B.N (Cubic Boron Nitride)

D Size	D Tolerance
$\varnothing 0.8 \sim 6$	+0 ~ -0.01mm

단위 : mm

Order Number	날경 Diameter D×R	날장 Length of cut L1	유효장 Effective Length L2	전장 Overall Length L	샤프크 Shank Dia d	비고	Order Number	날경 Diameter D×R	날장 Length of cut L1	유효장 Effective Length L2	전장 Overall Length L	샤프크 Shank Dia d	비고
4SCCBN 008 001 025	0.8 X R0.1	0.6	2.5	48	4		4SCCBN 030 003 100	3 X R0.3	1.2	10	66	6	
4SCCBN 008 002 025	0.8 X R0.2	0.6	2.5	48	4		4SCCBN 030 005 060	3 X R0.5	1.2	6	66	6	
4SCCBN 010 0002 025	1 X R0.02	0.7	2.5	48	4		4SCCBN 030 005 100	3 X R0.5	1.2	10	66	6	
4SCCBN 010 0002 040	1 X R0.02	0.7	4	48	4		4SCCBN 030 005 160	3 X R0.5	1.2	16	66	6	
4SCCBN 010 0005 025	1 X R0.05	0.7	2.5	48	4		4SCCBN 030 010 060	3 X R1	1.2	6	66	6	
4SCCBN 010 0005 040	1 X R0.05	0.7	4	48	4		4SCCBN 030 010 100	3 X R1	1.2	10	66	6	
4SCCBN 010 001 025	1 X R0.1	0.7	2.5	48	4		4SCCBN 030 010 160	3 X R1	1.2	16	66	6	
4SCCBN 010 001 040	1 X R0.1	0.7	4	48	4		4SCCBN 040 001 060	4 X R0.1	1.5	6	66	6	
4SCCBN 010 002 025	1 X R0.2	0.7	2.5	48	4		4SCCBN 040 001 100	4 X R0.1	1.5	10	66	6	
4SCCBN 010 002 040	1 X R0.2	0.7	4	48	4		4SCCBN 040 001 160	4 X R0.1	1.5	16	66	6	
4SCCBN 010 003 025	1 X R0.3	0.7	2.5	48	4		4SCCBN 040 002 060	4 X R0.2	1.5	6	66	6	
4SCCBN 010 003 040	1 X R0.3	0.7	4	48	4		4SCCBN 040 002 100	4 X R0.2	1.5	10	66	6	
4SCCBN 015 0002 030	1.5 X R0.02	0.8	3	48	4		4SCCBN 040 002 160	4 X R0.2	1.5	16	66	6	
4SCCBN 015 0002 040	1.5 X R0.02	0.8	4	48	4		4SCCBN 040 003 060	4 X R0.3	1.5	6	66	6	
4SCCBN 015 0005 030	1.5 X R0.05	0.8	3	48	4		4SCCBN 040 003 100	4 X R0.3	1.5	10	66	6	
4SCCBN 015 0005 040	1.5 X R0.05	0.8	4	48	4		4SCCBN 040 003 160	4 X R0.3	1.5	16	66	6	
4SCCBN 015 001 030	1.5 X R0.1	0.8	3	48	4		4SCCBN 040 005 060	4 X R0.5	1.5	6	66	6	
4SCCBN 015 001 040	1.5 X R0.1	0.8	4	48	4		4SCCBN 040 005 100	4 X R0.5	1.5	10	66	6	
4SCCBN 015 002 030	1.5 X R0.2	0.8	3	48	4		4SCCBN 040 005 160	4 X R0.5	1.5	16	66	6	
4SCCBN 015 002 040	1.5 X R0.2	0.8	4	48	4		4SCCBN 040 010 060	4 X R1	1.5	6	66	6	
4SCCBN 015 003 030	1.5 X R0.3	0.8	3	48	4		4SCCBN 040 010 100	4 X R1	1.5	10	66	6	
4SCCBN 015 003 040	1.5 X R0.3	0.8	4	48	4		4SCCBN 040 010 160	4 X R1	1.5	16	66	6	
4SCCBN 020 0002 030	2 X R0.02	0.9	3	50	4		4SCCBN 060 003 030	6 X R0.3	3	-	83	6	
4SCCBN 020 0002 040	2 X R0.02	0.9	4	50	4		4SCCBN 060 003 150	6 X R0.3	3	15	83	6	
4SCCBN 020 0002 060	2 X R0.02	0.9	6	50	4		4SCCBN 060 005 030	6 X R0.5	3	-	83	6	
4SCCBN 020 0005 030	2 X R0.05	0.9	3	50	4		4SCCBN 060 005 150	6 X R0.5	3	15	83	6	
4SCCBN 020 0005 040	2 X R0.05	0.9	4	50	4		4SCCBN 060 010 030	6 X R1	3	-	83	6	
4SCCBN 020 0005 060	2 X R0.05	0.9	6	50	4		4SCCBN 060 010 150	6 X R1	3	15	83	6	
4SCCBN 020 001 030	2 X R0.1	0.9	3	50	4								
4SCCBN 020 001 040	2 X R0.1	0.9	4	50	4								
4SCCBN 020 001 060	2 X R0.1	0.9	6	50	4								
4SCCBN 020 002 030	2 X R0.2	0.9	3	50	4								
4SCCBN 020 002 040	2 X R0.2	0.9	4	50	4								
4SCCBN 020 002 060	2 X R0.2	0.9	6	50	4								
4SCCBN 020 003 030	2 X R0.3	0.9	3	50	4								
4SCCBN 020 003 040	2 X R0.3	0.9	4	50	4								
4SCCBN 020 003 060	2 X R0.3	0.9	6	50	4								
4SCCBN 020 005 030	2 X R0.5	0.9	3	50	4								
4SCCBN 020 005 040	2 X R0.5	0.9	4	50	4								
4SCCBN 020 005 060	2 X R0.5	0.9	6	50	4								
4SCCBN 025 001 060	2.5 X R0.1	1.2	6	66	6								
4SCCBN 025 002 060	2.5 X R0.2	1.2	6	66	6								
4SCCBN 025 003 060	2.5 X R0.3	1.2	6	66	6								
4SCCBN 030 001 060	3 X R0.1	1.2	6	66	6								
4SCCBN 030 001 100	3 X R0.1	1.2	10	66	6								
4SCCBN 030 002 060	3 X R0.2	1.2	6	66	6								
4SCCBN 030 002 100	3 X R0.2	1.2	10	66	6								
4SCCBN 030 003 060	3 X R0.3	1.2	6	66	6								