

# Hülsen und Dorne

## Sleeves and arbors



Представництво в Україні:  
03067, м. Київ,  
вул. Машинобудівна, 46  
тел.: +38 044 227-57  
+38 044 394-80-94  
[www.fractalnost.com.ua](http://www.fractalnost.com.ua)



### ■ Inhalt:

- | Reduzierhülsen
- | Verlängerungshülsen
- | Bohrer- und Reibahlenverlängerungen
- | Reduzierhülsen für Hydrodehnspannfutter
- | Spindelhülsen
- | Klemmhülsen
- | Gewindebohrer-Spannhülsen
- | Gewindebohrerhalter mit Schnellwechselsystem
- | Kegeldorne

### ■ Content:

- | Reducing sleeves
- | Extension sleeves
- | Drill and reamer extensions
- | Reducing sleeves for hydraulic expansion mandrels
- | Spindle sleeves
- | Clamping sleeves
- | Tap holders
- | Tap holders with quick change mechanism
- | Taper arbors

## Reduzierhülsen Reducing sleeves

### DIN 2185, ganz gehärtet und geschliffen DIN 2185, completely hardened and ground



Außenkegel / External taper	Innenkegel / Internal taper	L mm	ca. g	Art.-Nr. / Order no.
1	0	80	30	01-52-1/0
2	1	92	95	01-52-2/1
3	1	99	190	01-52-3/1
3	2	112	250	01-52-3/2
4	1	124	550	01-52-4/1
4	2	124	480	01-52-4/2
4	3	140	360	01-52-4/3
5	1	156	1700	01-52-5/1
5	2	156	1520	01-52-5/2
5	3	156	1360	01-52-5/3
5	4	171	950	01-52-5/4
6	1	218	4400	01-52-6/1
6	2	218	4300	01-52-6/2
6	3	218	4100	01-52-6/3
6	4	218	3600	01-52-6/4
6	5	218	2550	01-52-6/5

## Verlängerungshülsen Extension sleeves

### DIN 2187, ganz gehärtet und geschliffen DIN 2187, completely hardened and ground

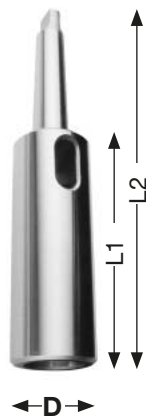

Außenkegel / External taper	Innenkegel / Internal taper	D mm	L1 mm	L2 mm	ca. g	Art.-Nr. / Order no.
1	1	20	83	145	190	01-65-1/1
1	2	30	98	160	340	01-65-1/2
2	1	20	85	160	250	01-65-2/1
2	2	30	100	175	400	01-65-2/2
2	3	36	121	196	840	01-65-2/3
2	4	48	145	220	1300	01-65-2/4
3	1	20	81	175	400	01-65-3/1
3	2	30	100	194	550	01-65-3/2
3	3	36	112	215	1000	01-65-3/3
3	4	48	146	240	1500	01-65-3/4
4	1	20	82,5	200	800	01-65-4/1
4	2	30	97,5	215	850	01-65-4/2
4	3	36	122,5	240	1300	01-65-4/3
4	4	48	147,5	265	1900	01-65-4/4
4	5	63	182,5	300	3310	01-65-4/5
5	1	20	82,5	232	1800	01-65-5/1
5	2	30	97,5	247	1900	01-65-5/2
5	3	36	118,5	268	2150	01-65-5/3
5	4	48	150,5	300	2750	01-65-5/4
5	5	63	182,5	335	4200	01-65-5/5
5	6	82	247	396	640	01-65-5/6
6	3	36	120	330	4580	01-65-6/3
6	4	48	180	355	5420	01-65-6/4
6	5	63	180	390	6750	01-65-6/5
6	6	82	241	451	11890	01-65-6/6

**Sonderhülsen auf Anfrage  
Special sleeves available upon request**

- Lagerstandard / in stock
- ▶ innerhalb weniger Tage / within a few days
- auf Anfrage / on request
- \* auslaufende Größe / as stock lasts

# Bohrer- und Reibahlen-Verlängerungen Drill and reamer extensions

**Ganz geschliffen, Kegel gehärtet**  
**Completely ground, taper hardened**

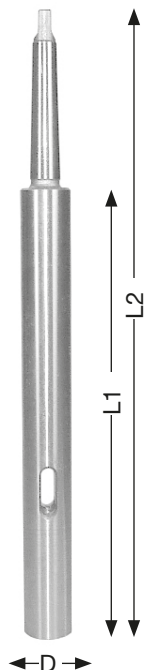

Außenkegel / External taper	Innenkegel / Internal taper	D mm	L1 mm	L2 mm	ca. g	Art.-Nr. / Order no.
1	1	20	138	200	250	01-75-1/1-200
1	1	20	188	250	375	01-75-1/1-250
1	1	20	238	300	500	01-75-1/1-300
1	1	20	288	350	625	01-75-1/1-350
1	1	20	338	400	750	01-75-1/1-400
1	1	20	388	450	900	01-75-1/1-450
1	1	20	438	500	1000	01-75-1/1-500
2	2	25	125	200	430	01-75-2/2-200
2	2	25	175	250	625	01-75-2/2-250
2	2	25	225	300	820	01-75-2/2-300
2	2	25	275	350	1015	01-75-2/2-350
2	2	25	325	400	1200	01-75-2/2-400
2	2	25	375	450	1400	01-75-2/2-450
2	2	25	425	500	1600	01-75-2/2-500
2	2	25	525	600	1800	01-75-2/2-600
3	3	32	156	250	1000	01-75-3/3-250
3	3	32	206	300	1300	01-75-3/3-300
3	3	32	256	350	1550	01-75-3/3-350
3	3	32	306	400	1850	01-75-3/3-400
3	3	32	356	450	2100	01-75-3/3-450
3	3	32	405	500	2400	01-75-3/3-500
3	3	32	506	600	2700	01-75-3/3-600
4	4	40	182,5	300	1650	01-75-4/4-300
4	4	40	232,5	350	2150	01-75-4/4-350
4	4	40	282,5	400	2650	01-75-4/4-400
4	4	40	332,5	450	3100	01-75-4/4-450
4	4	40	382,5	500	3600	01-75-4/4-500
4	4	40	482,5	600	4200	01-75-4/4-600

**Sonderhülsen auf Anfrage**  
**Special sleeves available upon request**

## Reduzierhülsen für Hydrodehnspannfutter Reducing sleeves for hydraulic expansion mandrels



Für die Reduzierung des Spanndurchmessers bei Hydrodehnspannfuttern.

For diameter reduction of hydraulic expansion mandrels.

**Kühlmitteldicht bis 60 bar**  
**Mechanically sealed up to 60 bar**

D mm	Bohrungen / Bores Ø mm	E mm	L mm	L1 mm	Art.-Nr. / Order no.
20	3, 4, 5, 6, 8, 10, 12, 14, 16	24	50,5	2	94-52-20/Ø
32	10, 12, 16, 18, 20, 25	36	60,5	3	94-52-32/Ø

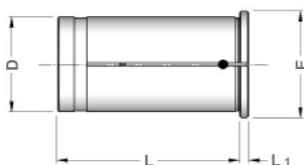

**Weitere Abmessungen auf Anfrage**  
**Further sizes available upon request**

## Spindelhülsen für Werkzeuge mit Morsekegel Spindle sleeves for tools with morse taper

### Mit Abdrückgewinde und Mutter With draw-off thread and nut

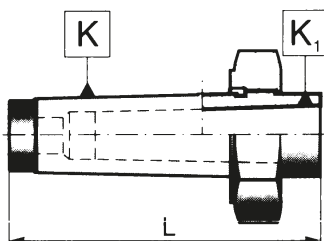

Außenkegel-MK / External taper-MT	Innenkegel-MK / Internal taper-MT	L mm	Art.-Nr. / Order no.
2*	1	84	● 01-84-2/1
3*	1	102	● 01-84-3/1
4*	1	122	● 01-84-4/1
3	2	102	● 01-84-3/2
4	2	122	● 01-84-4/2
4	3	122	● 01-84-4/3
5	2	153	● 01-84-5/2
5	3	153	● 01-84-5/3
5	4	153	● 01-84-5/4
6	3	212	✘ 01-84-6/3
6	4	212	● 01-84-6/4
6	5	212	● 01-84-6/5

\* mit Austreibschlitz  
\* with drift slot

## Spindelhülsen für Werkzeuge mit Morsekegel Spindle sleeves for tools with morse taper

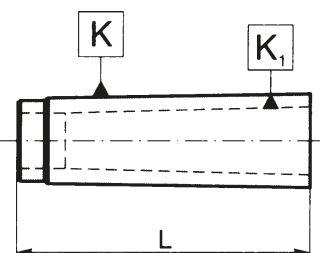

Außenkegel-MK / External taper-MT	Innenkegel-MK / Internal taper-MT	L mm	Art.-Nr. / Order no.
2	1	60	● 01-83-2/1
3	1	70	● 01-83-3/1
3	2	70	● 01-83-3/2
4	2	70	● 01-83-4/2
4	3	70	● 01-83-4/3
5	2	77	● 01-83-5/2
5	3	77	● 01-83-5/3
5	4	77	● 01-83-5/4
6	3	110	● 01-83-6/3
6	4	110	● 01-83-6/4
6	5	110	● 01-83-6/5
metrisch / metric 80	5	110	● 01-83-80/5
metrisch / metric 80	6	110	● 01-83-80/6
metrisch / metric 100	6	132	✘ 01-83-100/6

## Spindelhülsen zylindrisch für Werkzeuge mit Morsekegel Cylindrical spindle sleeves for tools with morse taper



Zylindrisch / Cylindrical	Morsekegel / Morse taper	L mm	Art.-Nr. / Order no.
16	1	90	● 01-85-16/1
25	2	95	● 01-85-25/2
30	3	115	● 01-85-30/3
40	4	152	● 01-85-40/4

- Lagerstandard / in stock
- ▶ innerhalb weniger Tage / within a few days
- auf Anfrage / on request
- ✘ auslaufende Größe / as stock lasts



# Klemmhülsen Clamping sleeves



Ganz gehärtet und geschliffen  
Completely hardened and ground

## Nach DIN 6328 für Gewindebohrer According to DIN 6328 for taps

MK / MT	Außen-Ø / External-Ø mm	L mm	Bohrung / Bore mm	Art.-Nr. / Order no.
1	12,2	65,5	2,5/2,8/ 3,5/4,0/4,5/5,0/ 5,5/6,0/7,0/8,0	● 06-501E-Ø
2	18,0	78,5	4,5/5,5/6,0/7,0/ 8,0/9,0/10,0/ 11,0/12,0/12,5	● 06-504E-Ø
3	24,0	98,0	8,0/9,0/10,0/ 11,0/12,0/ 12,5/14,0/16,0	● 06-535E-Ø
4	31,5	123,0	12,0/14,0/ 16,0/18,0/20,0/ 22,0/25,0	● 06-538E-Ø
5	44,7	156,0	22,0/25,0/28,0/ 30,0/32,0/36,0	● 06-589E-Ø

## Nach DIN 6329 für Spiralbohrer According to DIN 6329 for spiral drills

MK / MT	Außen-Ø / External-Ø mm	L mm	Abmessungen / Dimensions	Steigung / Pitch mm	Art.-Nr. / Order no.
1	12,2	65,5	3,0 - 8,0	0,5	● 06-511E-Ø
2	18,0	78,5	5,0 - 13,0	0,5	● 06-514E-Ø
3	24,0	98,0	10,0 - 16,0	1,0	● 06-545E-Ø
4	31,5	123,0	12,0 - 20,0	1,0	✘ 06-548E-Ø
5	44,7	156,0	20,0 - 36,0	1,0	✘ 06-599E-Ø

Weitere Abmessungen lieferbar auf Anfrage  
Further dimensions available upon request

### Für Maschinen mit steigungssynchronem Vorschub

### For machines with rigid tapping



- einsetzbar in herkömmlichen Weldon Spannfuttern nach DIN 1835 B
- kein Schlupf zwischen Hülse und Bohrer
- bei innerer Kühlmittelzufuhr 100% Kühlung an der Schneide
- suitable for standard Weldon chucks according to DIN 1835 B
- no slip between tap holder and drill
- 100% blade cooling if internal coolant supply is selected

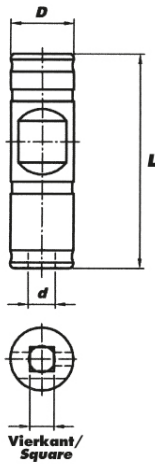

D mm	d mm	Vierkant / Square mm	L mm	Art.-Nr. / Order no.
8	2,5	2,1	27	● 81-GEW-8X2,5
8	2,8	2,1	27	● 81-GEW-8X2,8
10	3,5	2,7	35	● 81-GEW-10X3,5
10	4,0	3,0	35	● 81-GEW-10X4,0
10	4,5	3,4	35	● 81-GEW-10X4,5
12	6,0	4,9	45	● 81-GEW-12X6,0
14	7,0	5,5	45	● 81-GEW-14X7,0
14	8,0	6,2	45	● 81-GEW-14X8,0
16	9,0	7,0	48	● 81-GEW-16X9,0
16	10,0	8,0	48	● 81-GEW-16X10,0
18	11,0	9,0	48	● 81-GEW-18X11,0
20	12,0	9,0	50	● 81-GEW-20X12,0
25	14,0	11,0	56	● 81-GEW-25X14,0
25	16,0	12,0	56	● 81-GEW-25X16,0
32	18,0	14,5	60	● 81-GEW-32X18,0
32	20,0	16,0	60	● 81-GEW-32X20,0
32	22,0	18,0	60	● 81-GEW-32X22,0
40	25,0	20,0	70	● 81-GEW-40X25,0
40	28,0	22,0	70	● 81-GEW-40X28,0
50	32,0	24,0	80	● 81-GEW-50X32,0
50	36,0	29,0	80	● 81-GEW-50X36,0
50	40,0	32,0	80	● 81-GEW-50X40,0

# Gewindebohrerhalter mit Schnellwechselsystem

## Tap holders with quick change mechanism

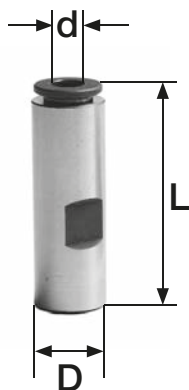

### Gewindebohrerhalter mit Weldon-Spannfläche

#### Tap holders for weldon chucks

- mit Innenvierkant
- für den Einsatz von Gewindebohrern in Weldonfuttern
- mit Schnellwechselsystem
- with internal square
- to use tapping collets in weldon chucks
- with quick change mechanism

D mm	d mm	Vierkant / Square mm	L mm	Art.-Nr. / Order no.
16	3,5	2,7	56	● 09-GBE-16/3,5
16	4,0	3,0	56	● 09-GBE-16/4,0
16	4,5	3,4	56	● 09-GBE-16/4,5
16	6,0	4,9	56	● 09-GBE-16/6,0
20	4,5	3,4	58	● 09-GBE-20/4,5
20	6,0	4,9	58	● 09-GBE-20/6,0
20	7,0	5,5	58	● 09-GBE-20/7,0
20	8,0	6,2	58	● 09-GBE-20/8,0
20	9,0	7,0	58	● 09-GBE-20/9,0
20	10,0	8,0	58	● 09-GBE-20/10
25	4,5	3,4	66	● 09-GBE-25/4,5
25	6,0	4,9	66	● 09-GBE-25/6,0
25	7,0	5,5	66	● 09-GBE-25/7,0
25	8,0	6,2	66	● 09-GBE-25/8,0
25	9,0	7,0	66	● 09-GBE-25/9,0
25	10,0	8,0	66	● 09-GBE-25/10,0
25	11,0	9,0	66	● 09-GBE-25/11,0
25	12,0	9,0	66	● 09-GBE-25/12,0
32	6,0	4,9	70	* 09-GBE-32/6,0
32	7,0	5,5	70	* 09-GBE-32/7,0
32	8,0	6,2	70	* 09-GBE-32/8,0
32	9,0	7,0	70	* 09-GBE-32/9,0
32	10,0	8,0	70	● 09-GBE-32/10,0
32	11,0	9,0	70	● 09-GBE-32/11,0
32	12,0	9,0	70	● 09-GBE-32/12,0
32	14,0	11,0	70	● 09-GBE-32/14,0
32	16,0	12,0	70	● 09-GBE-32/16,0
32	18,0	14,5	70	● 09-GBE-32/18,0

## DIN 238, Kegeldorne mit Morsekegelschaft DIN 238, taper arbors with morse taper shanks



Ganz gehärtet und geschliffen  
Completely hardened and ground

MK / MT	Kegel / Taper	L mm	ca. g	Art.-Nr. / Order no.
1	B 10	86	55	● 41-1/B10
1	B 12	90	60	● 41-1/B12
1	B 16	97	90	● 41-1/B16
1	B 18	105	110	● 41-1/B18
1	B 18 VK	97	95	✘ 41-1/B18VK
2	B 10	101	130	● 41-2/B10
2	B 12	105	135	● 41-2/B12
2	B 16	112	160	● 41-2/B16
2	B 18	120	180	● 41-2/B18
2	B 18 VK	108,5	165	✘ 41-2/B18VK
2	B 22	128	245	● 41-2/B22
3	B 12	124	280	● 41-3/B12
3	B 16	131	310	● 41-3/B16
3	B 18	139	320	● 41-3/B18
3	B 18 VK	132	320	✘ 41-3/B18VK
3	B 22	147	390	● 41-3/B22
3	B 24	157	440	● 41-3/B24
4	B 16	156	625	● 41-4/B16
4	B 18	164	660	● 41-4/B18
4	B 18 VK	159	640	✘ 41-4/B18VK
4	B 22	172	715	● 41-4/B22
4	B 24	182	770	● 41-4/B24
5	B 16	188	1600	● 41-5/B16
5	B 18	196	1600	● 41-5/B18
5	B 22	204	1650	● 41-5/B22
5	B 24	214	1700	● 41-5/B24

VK = verkürzter Bohrfutterkegel  
VK = shortened drill chuck taper

## Kegeldorne mit Zylinderschaft Taper arbors with cylinder shanks

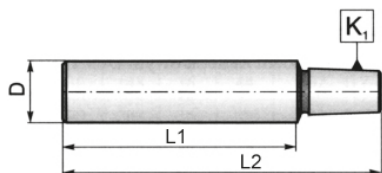

Ganz gehärtet und geschliffen  
Completely hardened and ground

D mm	L1 mm	Kegel / Taper	L2 mm	Art.-Nr. / Order no.
8	35	B 10	55	● 13-5348-8-35-B10
10	50	B 10	70	● 13-5348-10-50-B10
10	50	B 12	75	● 13-5348-10-50-B12
10	50	B 16	82	● 13-5348-10-50-B16
12	50	B 16	82	● 13-5348-12-50-B16
12	60	B 16	92	● 13-5348-12-60-B16
16	50	B 16	81	● 13-5348-16-50-B16
16	70	B 16	101	● 13-5348-16-70-B16
16	70	B 18	110	✘ 13-5348-16-70-B18
20	60	B 12	87	● 13-5348-20-60-B12
20	60	B16	93	● 13-5348-20-60-B16
20	60	B 18	100	● 13-5348-20-60-B18
25	75	B 16	107	● 13-5348-25-75-B16
30	70	B 16	106	✘ 13-5348-30-70-B16
30	70	B 18	112	✘ 13-5348-30-70-B18



## Kegeldorne mit Jacobs-Kegel Taper arbors with Jacobs taper

### Typ 236 Type 236

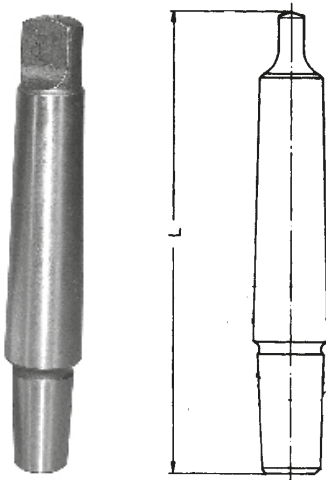

Ganz gehärtet und geschliffen  
Completely hardened and ground

MK / MT	Kegel / Taper	L mm	Art.-Nr. / Order no.
1	J1	85	* 41-1/J1
1	J2	90	● 41-1/J2
1	J3	99	● 41-1/J3
1	J6	94	● 41-1/J6
2	J1	100	* 41-2/J1
2	J2	105	● 41-2/J2
2	J3	114	● 41-2/J3
2	J6	108	● 41-2/J6
3	J2	124	● 41-3/J2
3	J3	133	● 41-3/J3
3	J33	127	● 41-3/J33
3	J4	144	● 41-3/J4
3	J6	127	● 41-3/J6
4	J3	158	● 41-4/J3
4	J6	152	● 41-4/J6

## Kegeldorne mit Morsekegel und Anzugsgewinde Taper arbors with morse taper and internal thread

### DIN 228 A DIN 228 A

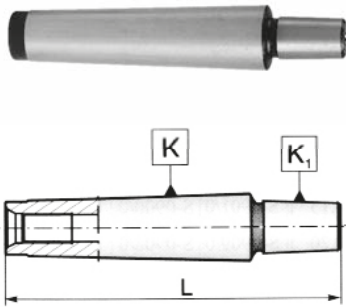

MK / MT	L mm	Gewinde / Thread	Kegel / Taper	Art.-Nr. / Order no.
2	90	M 10	B 10	● 41-2/B10-M10
2	95	M 10	B 12	● 41-2/B12-M10
2	101	M 10	B 16	● 41-2/B16-M10
3	121	M 12	B 16	● 41-3/B16-M12
4	143	M 16	B 16	● 41-4/B16-M16

## Kegeldorne mit Gewinde Taper arbors with thread



MK / MT	Gewinde / Thread	L mm	kg	Art.-Nr. / Order no.
2	3/8-24	101	0,2	● 41-2-3/8-24
2	1/2-20	104	0,2	● 41-2-1/2-20
2	5/8-16	106	0,2	● 41-2-5/8-16
3	M20	122	0,4	● 41-3-3/M20

# Kegelhülsen Conic bushes

## Kegelhülsen, zylindrisch mit Innenkegel (MK) Conic bushes, cylindrical with internal taper (MT)

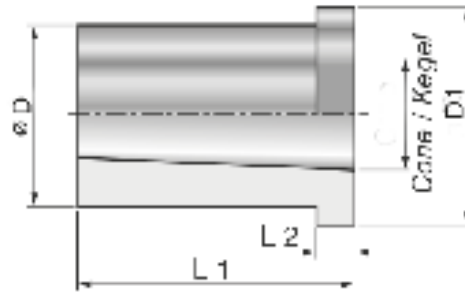
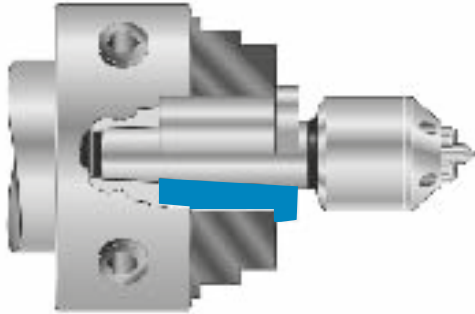

MK / MT	L1 mm	L2 mm	$\varnothing D$ mm	D1 mm	kg	Art.-Nr. / Order no.
3	65	8	35	44	0,3	▶ 03-KH-3
4	70	8	42	49	0,45	▶ 03-KH-4
5	80	10	54	59	0,6	▶ 03-KH-5
6	85	10	75	84	0,75	▶ 03-KH-6