

Ausdrehkopf-Sätze und Gewindeschneidfutter

Boring head sets and tapping chucks



Представництво в Україні:
03067, м. Київ,
вул. Машинобудівна, 46
тел.: +38 044 227-57
+38 044 394-80-94
www.fractalnost.com.ua



■ Inhalt:

12.1 | Ausdrehkopf-Sätze

12.2 | Gewindeschneidfutter

- | Gewindeschneid-Schnellwechselfutter
- | Synchron-Gewindeschneidfutter
- | Gewindeschneidapparate mit autom. Rücklauf

■ Content:

12.1 | Boring head sets

12.2 | Tapping chucks

- | Quick-change tapping chucks
- | Synchro-tapping chucks
- | Reversal tapping heads



Ausdrehkopf-Sätze Boring head sets

12
12.1



Typ AKS 2G, Ausdrehbereich Ø 10 mm - 240 mm Type AKS 2G, boring capacity Ø 10 mm - 240 mm

- Skala 0,01 mm
- Lieferumfang: Ausdrehkopf, 4 Bohrstangen, 1 Ausdrehwerkzeug, je 1 Sechskantschlüssel 3, 4 und 6 mm
- scale 0,01 mm
- scope of delivery: boring head, 4 boring bars, 1 boring tool, hexagon wrench 3, 4 and 6 mm one each

Schaft / Shank	Bohrtiefe max. / Depth max. mm	kg	Art.-Nr. / Order no.
BT 40	120	6	09-AKS2G-BT40
DIN 69871 / SK 40	120	6,5	09-AKS2G-SK40
MK / MT 3	120	7,5	09-AKS2G-MK3
MK / MT 4	120	7	09-AKS2G-MK4



Typ AKS 1, Ausdrehbereich Ø 8 mm - 46 mm Type AKS 1, boring capacity Ø 8 mm - 46 mm

- Skala 0,005 mm
- Gesamt-Vorschub: 6 mm
- Lieferumfang: Ausdrehkopf, 8 Bohrstangen Ø 16 mm, Befestigungsschrauben, Bedienschlüssel
- scale 0,005 mm
- total stroke: 6 mm
- scope of delivery: boring head, 8 boring bars Ø 16 mm, screws, setting tool

Schaft / Shank	Bohrtiefe max. / Depth max. mm	kg	Art.-Nr. / Order no.
BT 40	90	7	09-AKS1-BT40
BT 50	90	8	09-AKS1-BT50
DIN 69871 / SK 40	90	7	09-AKS1-SK40
DIN 69871 / SK 50	90	8	09-AKS1-SK50



Typ AKS 2, Ausdrehbereich Ø 8 mm - 280 mm Type AKS 2, boring capacity Ø 8 mm - 280 mm

- Skala 0,005 mm
- Gesamt-Vorschub: 27 mm
- Lieferumfang: Ausdrehkopf, 8 Bohrstangen Ø 20 mm, Befestigungsschrauben, Bedienschlüssel
- scale 0,005 mm
- total stroke: 27 mm
- scope of delivery: boring head, 8 boring bars Ø 20 mm, screws, setting tool

Schaft / Shank	Bohrtiefe max. / Depth max. mm	kg	Art.-Nr. / Order no.
BT 40	115	8	09-AKS2-BT40
BT 50	115	10	09-AKS2-BT50
DIN 69871 / SK 40	115	8	09-AKS2-SK40
MK / MT 3	115	7	09-AKS2-MK3
MK / MT 4	115	7	09-AKS2-MK4
MK / MT 5	115	8	09-AKS2-MK5

Passende Wendschneidplatten Suitable inserts

AKS 2G Ausdrehbereich / Boring capacity	AKS 1 Ausdrehbereich / Boring capacity	AKS 2 Ausdrehbereich / Boring capacity	Wendschneidplatten / Inserts	Art.-Nr. / Order no.
Ø 10 - 240 mm	Ø 8 - 13 mm	Ø 8 - 13 mm	TBGT060102L	1M-TBGT060102L
-	Ø 12 - 15 mm	Ø 12 - 21 mm	TPGH090204L	1M-TPGH090204L
-	Ø 16 - 46 mm	Ø 20 - 280 mm	TPGH110304L	1M-TPGH110304L

Preis pro Stück. Abgabe nur in VE à 10 Stück
Price per piece. Only available in sets of 10 pieces

- Lagerstandard / in stock
- ▶ innerhalb weniger Tage / within a few days
- auf Anfrage / on request
- * auslaufende Größe / as stock lasts



Gewindeschneid-Schnellwechselfutter

Quick-change tapping chucks

Gewindeschneid-Schnellwechselfutter mit Morsekegel, mit Längenausgleich auf Zug und Druck

Quick-change tapping chucks with morse taper shank, with length compensation

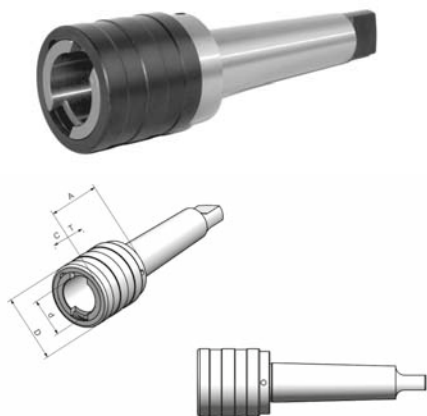

MK / MT	Größe / Size	Bereich / Range	A mm	D mm	D1 mm	Zug / Ext. mm	Druck / Compr. mm	Art.-Nr. / Order no.
MK / MT 2	1	M3 - M14	46	38	19	7,5	7,5	76-GSSF-MK2/1
MK / MT 3	1	M3 - M14	46	38	19	7,5	7,5	76-GSSF-MK3/1
MK / MT 3	2	M5 - M22	69	55	31	12,5	12,5	76-GSSF-MK3/2
MK / MT 4	2	M5 - M22	70	55	31	12,5	12,5	76-GSSF-MK4/2
MK / MT 4	3	M14 - M36	108	79	48	20	20	76-GSSF-MK4/3
MK / MT 5	3	M14 - M36	103	79	48	20	20	76-GSSF-MK5/3

Gewindeschneid-Schnellwechselfutter DIN 2080, mit Längenausgleich auf Zug und Druck

Quick-change tapping chucks DIN 2080, with length compensation

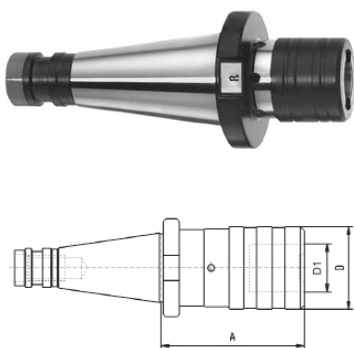

SK	Größe / Size	Bereich / Range	A mm	D mm	D1 mm	Art.-Nr. / Order no.
SK 40	1	M3 - M14	59	38	19	76-GSSF-ISO40/1
SK 40	2	M5 - M22	97	54	31	76-GSSF-ISO40/2
SK 40	3	M14 - M36	142	78	48	76-GSSF-ISO40/3
SK 50	1	M3 - M14	50	38	19	76-GSSF-ISO50/1
SK 50	2	M5 - M22	82	54	31	76-GSSF-ISO50/2
SK 50	3	M14 - M36	128	78	48	76-GSSF-ISO50/3

Gewindeschneid-Schnellwechselfutter DIN 69871, mit Längenausgleich auf Zug und Druck

Quick-change tapping chucks DIN 69871, with length compensation



SK	Größe / Size	Bereich / Range	A mm	D mm	D1 mm	Art.-Nr. / Order no.
SK 40	1	M3 - M14	59	38	19	76-GSSF-SK40/1
SK 40	2	M5 - M22	97	54	31	76-GSSF-SK40/2
SK 40	3	M14 - M36	156	78	48	76-GSSF-SK40/3
SK 50	1	M3 - M14	63	38	19	76-GSSF-SK50/1
SK 50	2	M5 - M22	97	54	31	76-GSSF-SK50/2
SK 50	3	M14 - M36	140	78	48	76-GSSF-SK50/3

Gewindeschneid-Schnellwechselfutter MAS BT, mit Längenausgleich auf Zug und Druck

Quick-change tapping chucks MAS BT, with length compensation

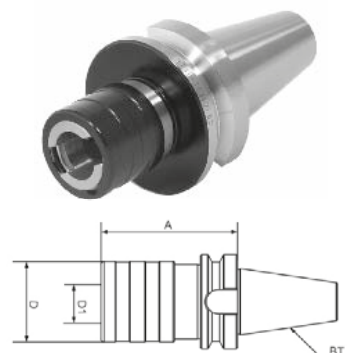

MAS BT	Größe / Size	Bereich / Range	A mm	D mm	D1 mm	Art.-Nr. / Order no.
BT 40	1	M3 - M14	65	38	19	76-GSSF-BT40/1
BT 40	2	M5 - M22	93	54	31	76-GSSF-BT40/2
BT 40	3	M14 - M36	166	78	48	76-GSSF-BT40/3
BT 50	1	M3 - M14	100	38	19	76-GSSF-BT50/1
BT 50	2	M5 - M22	100	54	31	76-GSSF-BT50/2
BT 50	3	M14 - M36	142	78	48	76-GSSF-BT50/3

Passende Einsätze siehe Seite 253
Suitable inserts see page 253

Gewindeschneid-Schnellwechselfutter Quick-change tapping chucks

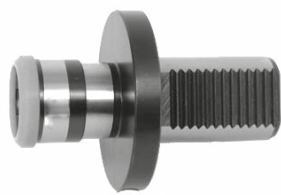

Gewindeschneid-Schnellwechselfutter VDI (DIN 69880), mit Längenausgleich auf Zug und Druck Quick-change tapping chucks VDI (DIN 69880), with length compensation

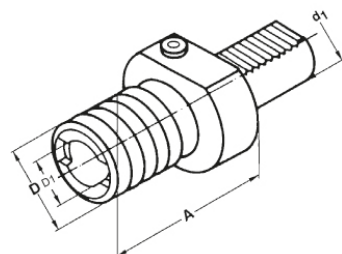

VDI	Größe / Size	Bereich / Range	A mm	D mm	D1 mm	Art.-Nr. / Order no.
VDI 20	1	M3 - M14	55	38	19	76-GSSF-VDI20/1
VDI 25	1	M3 - M14	55	38	19	76-GSSF-VDI25/1
VDI 30	1	M3 - M14	55	38	19	76-GSSF-VDI30/1
VDI 30	2	M5 - M22	77	54	31	76-GSSF-VDI30/2
VDI 40	1	M3 - M14	55	38	19	76-GSSF-VDI40/1
VDI 40	2	M5 - M22	77	54	31	76-GSSF-VDI40/2
VDI 40	3	M14 - M36	108	78	48	76-GSSF-VDI40/3
VDI 50	2	M5 - M22	77	54	31	76-GSSF-VDI50/2
VDI 50	3	M14 - M36	108	78	48	76-GSSF-VDI50/3

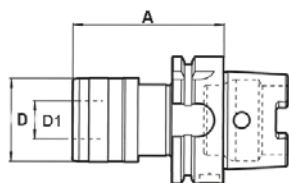

Gewindeschneid-Schnellwechselfutter DIN 69893 HSK - A, mit Längenausgleich auf Zug und Druck Quick-change tapping chucks DIN 69893 HSK - A, with length compensation

HSK	Größe / Size	Bereich / Range	A mm	D mm	D1 mm	Art.-Nr. / Order no.
HSK-50A	1	M3 - M14	72	41	19	76-GSSF-HSK50A/1
HSK-50A	2	M5 - M22	110	60	31	76-GSSF-HSK50A/2
HSK-63A	1	M3 - M14	72	41	19	76-GSSF-HSK63A/1
HSK-63A	2	M5 - M22	110	60	31	76-GSSF-HSK63A/2

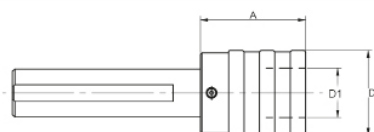

Gewindeschneid-Schnellwechselfutter zylindrisch, mit Längenausgleich auf Zug und Druck Quick-change tapping chucks cylindrical, with length compensation

Schaft-Ø / Shank-Ø	Größe / Size	Bereich / Range	A mm	D mm	D1 mm	Art.-Nr. / Order no.
20	1	M3 - M14	40	36	19	76-GSSF-ZYL20/1
25	1	M3 - M14	40	36	19	76-GSSF-ZYL25/1
25	2	M5 - M22	64	53	31	76-GSSF-ZYL25/2
32	2	M5 - M22	64	53	31	76-GSSF-ZYL32/2
32	3	M14 - M36	97	78	48	76-GSSF-ZYL32/3

Passende Einsätze siehe Seite 253
Suitable inserts see page 253

Gewindeschneid-Schnellwechseleinsätze Quick-change tapping inserts



Mit Rutschkupplung With safety clutch

Größe / Size	Bereich / Thread	Art.-Nr. / Order no.
0	M1 - M10	76-GEM0-M...
1	M3 - M14	76-GEM1-M...
2	M5 - M22	76-GEM2-M...
3	M14 - M36	76-GEM3-M...
4	M24 - M48	76-GEM4-M...



Ohne Rutschkupplung Without safety clutch

Größe / Size	Bereich / Thread	Art.-Nr. / Order no.
0	M1 - M10	76-GEO0-M...
1	M2 - M2,5	76-GEO1-M...
1	M3 - M14	76-GEO1-M...
2	M5 - M22	76-GEO2-M...
3	M14 - M36	76-GEO3-M...

Reduzierungen für Gewindeschneid-Schnellwechseleinsätze Reductions sleeves for quick-change tapping inserts

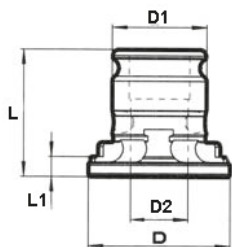

Von Größe auf Größe / From size to size	D1 mm	D2 mm	D mm	L mm	L1 mm	Art.-Nr. / Order no.
1/0	19	13	30	21,5	6	76-SRE-1/0
2/1	31	19	46	35	8,5	76-SRE-2/1
3/1	48	19	68	55,5	7	76-SRE-3/1
3/2	48	31	68	55,5	7	76-SRE-3/2

Synchron-Gewindeschneidfutter

Synchro-tapping chucks

- zum Gewindeschneiden auf Bearbeitungszentren mit Synchronsteuerung
- Micro-Längenausgleich auf Zug (1 mm) und Druck (0,2 mm)
- passende Schnellwechseleinsätze siehe Seite 255
- for synchronized tapping
- micro compensation: in extension (1 mm), in compression (0,2 mm)
- suitable inserts see page 255

Grundkörper DIN 69893 HSK - A

Base body DIN 69893 HSK - A

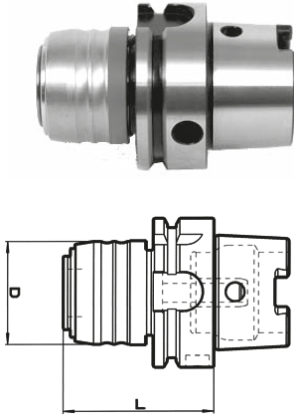

Größe / Size	D1 mm	D mm	L mm	Bereich / Tap capacity	Art.-Nr. / Order no.
HSK-40A	20	43	69	M3-M12	76-SYNC-HSKA40/1
HSK-50A	20	43	70	M3-M12	76-SYNC-HSKA50/1
HSK-63A	20	43	64	M3-M12	76-SYNC-HSKA63/1
HSK-100A	20	43	70	M3-M12	76-SYNC-HSKA100/1
HSK-40A	32	60	90	M6-M20	76-SYNC-HSKA40/2
HSK-50A	32	60	97	M6-M20	76-SYNC-HSKA50/2
HSK-63A	32	60	97	M6-M20	76-SYNC-HSKA63/2
HSK-100A	32	60	91	M6-M20	76-SYNC-HSKA100/2
HSK-100A	50	87	115	M14-M33*	76-SYNC-HSKA100/3

* Längenausgleich auf Zug (2 mm) und Druck (0,4 mm)
 * compensation in extension (2 mm) and in compression (0,4 mm)

Grundkörper DIN 69871

Base body DIN 69871

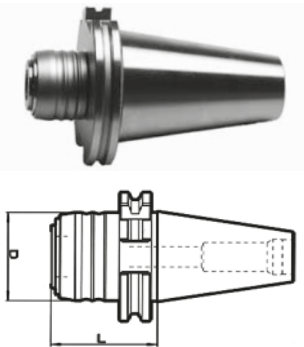

Größe / Size	D1 mm	D mm	L mm	Bereich / Tap capacity	Art.-Nr. / Order no.
SK 40	20	43	53	M3-M12	76-SYNC-SK40/1
SK 50	20	43	53	M3-M12	76-SYNC-SK50/1
SK 40	32	60	90	M6-M20	76-SYNC-SK40/2
SK 50	32	60	74	M6-M20	76-SYNC-SK50/2

Grundkörper MAS BT

Base body MAS BT

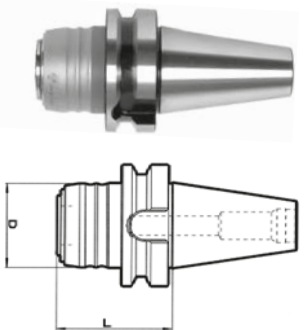

Größe / Size	D1 mm	D mm	L mm	Bereich / Tap capacity	Art.-Nr. / Order no.
BT 40	20	43	61	M3-M12	76-SYNC-BT40/1
BT 50	20	43	72	M3-M12	76-SYNC-BT50/1
BT 40	32	60	82	M6-M20	76-SYNC-BT40/2
BT 50	32	60	93	M6-M20	76-SYNC-BT50/2

Grundkörper DIN 69880

Base body DIN 69880

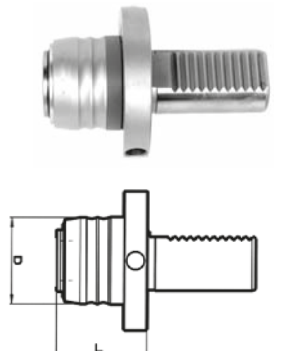

Größe / Size	D1 mm	D mm	L mm	Bereich / Tap capacity	Art.-Nr. / Order no.
VDI 30	20	43	46	M3-M12	76-SYNC-VDI30/1
VDI 40	20	43	46	M3-M12	76-SYNC-VDI40/1
VDI 30	32	60	67	M6-M20	76-SYNC-VDI30/2
VDI 40	32	60	67	M6-M20	76-SYNC-VDI40/2

Weitere Grundkörper auf Anfrage
 Further base bodies upon request



Schnellwechseleinsätze für Synchron-Gewindeschneidfutter

Tapping inserts for synchro-tapping chucks

Schnellwechseleinsatz

Tapping inserts

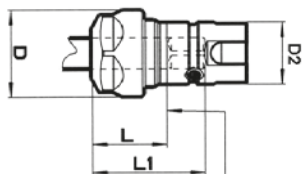

- Verdrehsicherung durch Schrauben - locking by screws
- keine Gewindebohrzangen notwendig - no need to use tapping collets

D2 mm	D mm	L mm	L1 mm	Bereich / Tap capacity	Für Spannzangen / For collets	Art.-Nr. / Order no.
20*	28	24	37	M3-M12	ER 16 (1-10)	▶ 76-SYNC-SE1
32	42	28	52	M6-M20	ER 25 (2-16)	▶ 76-SYNC-SE2
50	63	32	75	M14-M33	ER 40 (3-30)	▶ 76-SYNC-SE3

* Lieferung mit Sechskantmutter
* Supplied with hexagonal nut

Verlängerter Schnellwechseleinsatz

Extended tapping inserts

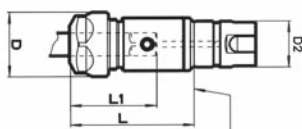

- schlanke Version, für beengte Platzverhältnisse geeignet - extra slim for limited space conditions

D2 mm	D mm	L mm	L1 mm	Bereich / Tap capacity	Für Spannzangen / For collets	Art.-Nr. / Order no.
20*	28	55	38	M3-M12	ER 16 (1-10)	▶ 76-SYNC-VSE1
32	42	86	63	M6-M20	ER 25 (2-16)	▶ 76-SYNC-VSE2
50	63	95	73	M14-M33	ER 40 (3-30)	▶ 76-SYNC-VSE3

* Lieferung mit Sechskantmutter
* Supplied with hexagonal nut

Weitere Verlängerungen und Endstücke auf Anfrage
Further extensions and end pieces upon request

Montagebeispiel

Example

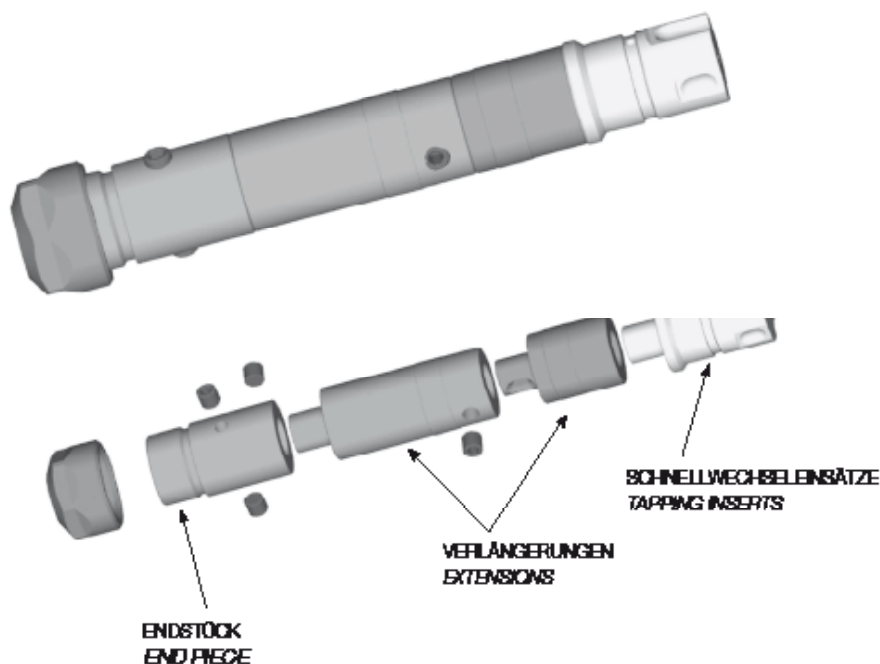

Gewindeschneidapparate mit automatischem Rücklauf

Reversal tapping chucks



Gewindeschneidapparate BASIC

Reversal tapping chucks BASIC

- mit automatischem Vorschub
 - eingebauter Schnellrücklauf 1,75 : 1
 - einstellbare Sicherheits-Rutschkupplung
 - Längenausgleich auf Druck und Zug
- *automatic feed*
 - *rapid reversal 1,75 : 1*
 - *adjustable safety clutch*
 - *length compensation*

Scope of delivery: incl. 2 multi-range collets and all required wrenches

Lieferumfang: 2 Mehrbereichs-Spannzangen und alle notwendigen Schlüssel

Größe / Size	Aufnahme / Mounting	Bereich / Capacity	Ø D mm	Max. Drehmoment / Max. torque Nm	Max. Drehzahl / Max. speed RPM	Art.-Nr. / Order no.
7	B16	M2 - M7	55	14	1500	● BAS-GSA-M7
12	B16	M5 - M12	75	65	1000	● BAS-GSA-M12
20	B22	M8 - M20	91	125	600	● BAS-GSA-M20

Passende Kegeldorne siehe Seiten 104 - 105
 Suitable taper arbors see pages 104 - 105

Mehrbereich-Spannzangen

Multi-range collets

- für Gewindeschneidapparate
- for reversal tapping chucks

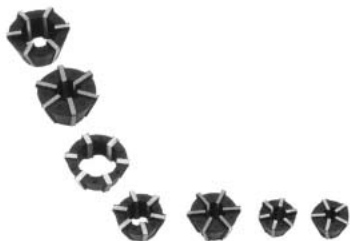

Größe / Size	Bereich / Capacity	Spannbereich / Clamping capacity	Art.-Nr. / Order no.
7	M2 - M7	Ø 2,5-4,2	● 06-RF7-4,5
7	M4 - M7	Ø 4,2-6,5	● 06-RF7-6,5
12	M5 - M8	Ø 3,5-7	● 06-RF12-7,0
12	M8 - M12	Ø 7,0-10,0	● 06-RF12-10,0
20	M8 - M14	Ø 6,0-9,0	● 06-RF20-9,0
20	M14 - M20	Ø 9,0-14,0	● 06-RF20-14,0