

Schnellwechselstahl- und Schleifbandhalter

Quick-change tool holders and sanding belt holders

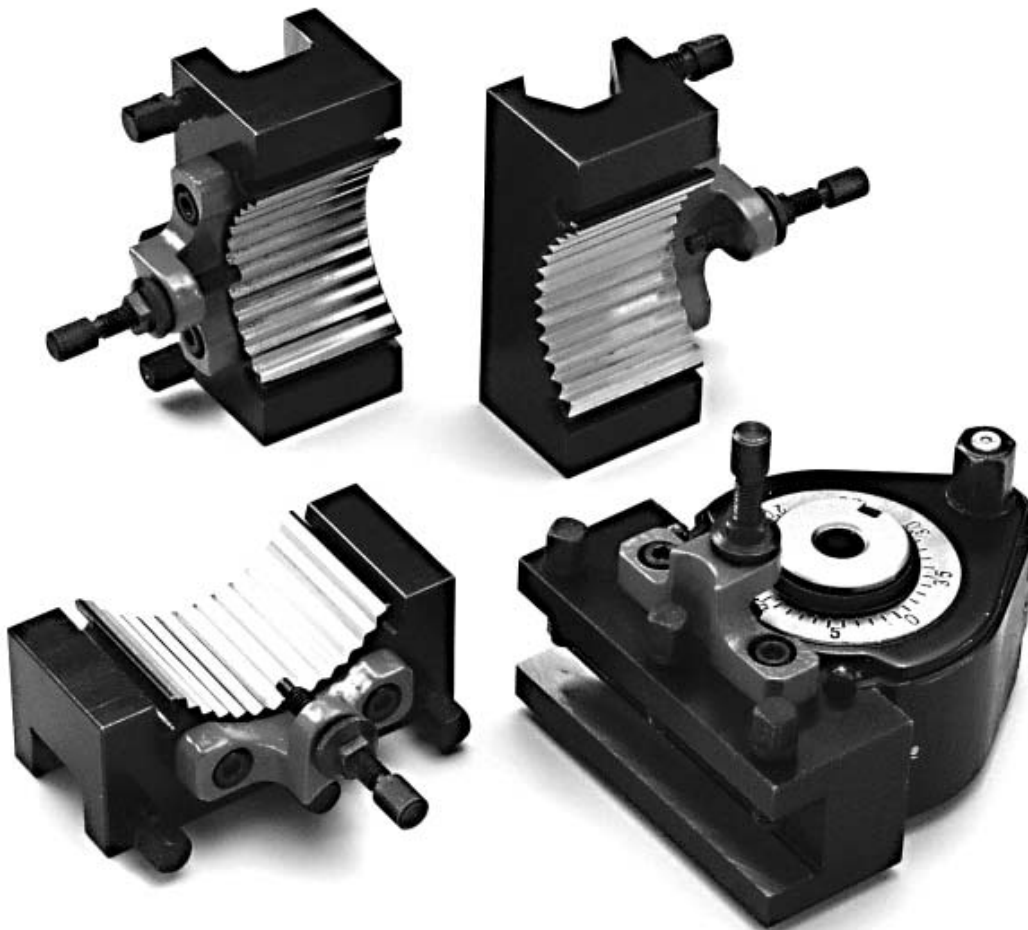

Представництво в Україні:
03067, м. Київ,
вул. Машинобудівна, 46
тел.: +38 044 227-57
+38 044 394-80-94
www.fractalnost.com.ua



ORIGINALMULTISUISSE®



■ Inhalt:

- | Schnellwechselstahlhalter
- | Schleifbandhalter

■ Content:

- | Quick-change tool holders
- | Sanding belt holders



Technische Daten Technical Data

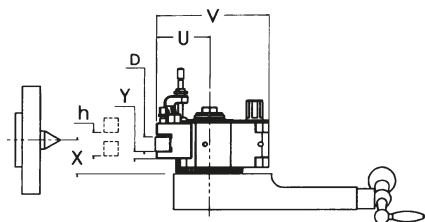

Bei der Wahl der Größe ist zu beachten:

1. Antriebsleistung der Drehbank
2. Spitzenhöhe ab Querschlitten „X“
3. Die Länge des Wechselhalters „lg“ soll möglichst der Breite „Z“ des Querschlittens entsprechen
4. Die zu verwendende Stahlhöhe „D“ ergibt zusammen mit der Stahlauflage „Y“ und dem darunter verbleibenden Zwischenraum das erforderliche Maß „X“ (siehe Tabelle)

Pay attention to the following details to find the correct size:

1. Driving motor power
2. Centers height from carriage „X“
3. Length of toolholder „lg“ should possibly correspond to width „Z“ of top slide
4. Height of tool „D“, which together with height „Y“ and the space that remains underneath makes up the necessary size „X“ (see table)

Typ / Type	Aa	A	A	E	E	E	B	B	C	C	C	D1	D1	D1	D2	D2	
Stahlhalter D / Toolholder D →	12	16	20	16	20	25	25	32	32	40	45	40	50	63	50	63	
Stahlhöhe D / Tool height D ↓	X min.																
6	12																
8	14	17															
10	16	19	19	19	19	22											
12	18	21	21	21	21	24	25	26									
(14)		23	23	23	23	26	27	28	29								
16		25	25	25	25	28	29	30	31	31							
20						29	32	33	34	35	35	38					
25							37	38	39	40	40	43	45				
(30)									44	45	45	48	50	51	52	50	55
32										47	47	50	52	53	54	52	57
40											55	58	60	61	62	60	65
50													71	72	70	75	
63														85		88	

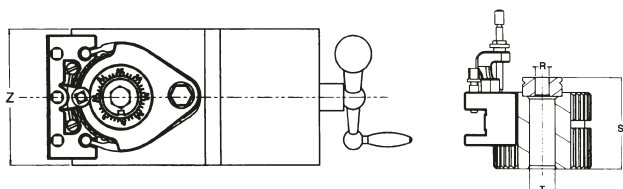

Die Bohrung „R“ in der Zentrierscheibe muss auf das Maß der Spannschraube vergrößert werden.

Hole „R“ in the centring disc must be enlarged up to the size of the clamping screw.

Typ / Type	Aa	A	A	E	E	E	B	B	C	C	C	D1	D1	D1	D2	D2	
Antriebsleistung / Driving power	KW	1	2		4,5		7		13			20			28		
Wechselhalter-Größe / Change toolholder size	D	12	16	20	16	20	25	25	32	32	40	45	40	50	63	50	63
Schlittenbreite max / Max. carriage width	Z mm	80	100		120		150		180			200			250		
Spitzenhöhe ab Querschlitten min. / Min. centers height from carriage	X min	18	24,5	28,5	24,5	28,5	37	37	45,5	47	55	63	60	70	83	70	88
Spitzenhöhe ab Querschlitten max. / Max. centers height from carriage	X max	26	35,5	39,5	40,5	39,5	43	57	56,5	87	90	93	95	100	103	90	118
Höhenverstellbarkeit / Height adjustability	h mm	8	11		16	11	6	20	11	40	35	30	35	30	20	20	30
Stahlauflage / Tool repose	Y mm	6	8,5	8,5	8,5	8,5	12	12	13,5	15	15	18	20	20	25	20	25
Höhe des Arbeitsstahls max. / Max. tool height	D mm	12	16	20	16	20	25	25	32	32	40	45	40	50	63	50	65
Gesamtbreite max. / Total width	V mm	70	100		125		150		200			230	234	242	275	282	
Gesamthöhe / Total height	S mm	37	56		68		79		110			122			135		
Ausladung max. / Max. distance	U mm	30	48		60		71		90			112	116	124	140	147	
Bohrung Ø max. / Boring Ø max.	T mm	13	20		20		32		40			40			80		



Schnellwechselstahlhalter, ORIGINAL MULTISUISSE® Quick-change tool holders, ORIGINAL MULTISUISSE®

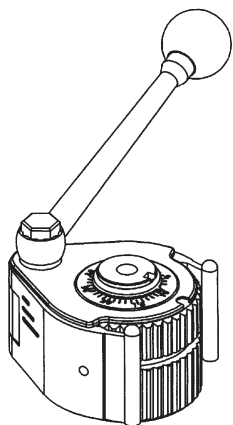

ORIGINAL MULTISUISSE®

Stahlhalterkopf Turret

Größe / Size	Art.-Nr. / Order no.
Aa	● 50-100-100
A	● 50-100-106
E	● 50-100-123
B	● 50-100-141
C	● 50-100-156
D1	● 50-100-177
D2	▶ 50-100-186

ORIGINAL MULTISUISSE®

Drehstahlhalter D Tool holder D

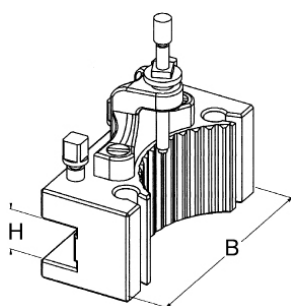

Typ / Type	Für Kopf / For turret	H mm	B mm	Art.-Nr. / Order no.
AaD	Aa	12	50	● 50-100-101
AD	A	16	75	● 50-100-107
AD	A	16	90	● 50-100-108
AD	A	20	75	● 50-100-109
AD	A	20	90	● 50-100-110
ED	E	16	100	● 50-100-124
ED	E	20	100	● 50-100-125
ED	E	25	100	● 50-100-126
BD	B	25	120	● 50-100-142
BD	B	25	140	● 50-100-143
BD	B	32	120	● 50-100-144
BD	B	32	140	● 50-100-145
CD	C	32	150	● 50-100-157
CD	C	32	170	● 50-100-158
CD	C	40	150	● 50-100-159
CD	C	40	170	● 50-100-160
CD	C	45	170	● 50-100-161
D1D	D1	40	180	● 50-100-178
D1D	D1	50	180	● 50-100-179
D1D	D1	63	180	● 50-100-180
D2D	D2	50	220	▶ 50-100-187
D2D	D2	63	220	▶ 50-100-188

ORIGINAL MULTISUISSE®

Bohrstahlhalter H Bar holder H

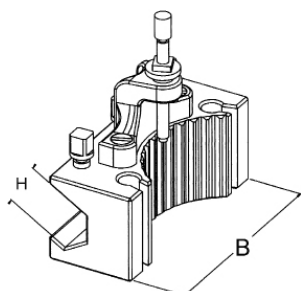

Typ / Type	Für Kopf / For turret	H mm	B mm	Art.-Nr. / Order no.
AaH	Aa	12	50	● 50-100-102
AH	A	20	85	● 50-100-111
EH	E	16	100	● 50-100-127
EH	E	25	100	● 50-100-128
BH	B	32	130	● 50-100-146
CH	C	40	160	● 50-100-162
CH	C	50	160	● 50-100-163
D1H	D1	63	180	● 50-100-181
D2H	D2	70	220	▶ 50-100-189



Schnellwechselstahlhalter, ORIGINAL MULTISUISSE® Quick-change tool holders, ORIGINAL MULTISUISSE®

ORIGINALMULTISUISSE®

Bohrstangenhalter J Bush holder J

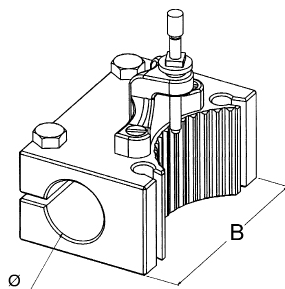

Typ / Type	Für Kopf / For turret	Ø mm	B mm	Art.-Nr. / Order no.
AaJ	Aa	15	50	● 50-100-103
AJ	A	30	80	● 50-100-112
EJ	E	30	100	● 50-100-129
EJ	E	40	100	● 50-100-130
BJ	B	40	120	● 50-100-147
CJ	C	40	160	● 50-100-164
CJ	C	50	160	● 50-100-165
D1J	D1	63	180	● 50-100-182
D2J	D2	63	220	▶ 50-100-190

ORIGINALMULTISUISSE®

Abstechhalter T Cutting-off holder T

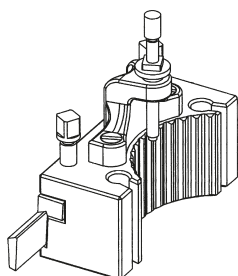

Typ / Type	Für Kopf / For turret	Stahlgröße / Cutting tool size mm	Art.-Nr. / Order no.
AaT	Aa	2,5 x 10	● 50-100-104
AT-K	A	2,7 x 10	● 50-100-113
ET-K	E	4 x 16	● 50-105-131
BT-K	B	4 x 16	● 50-100-148
CT-K	C	5,1 x 18,5	● 50-100-166

ORIGINALMULTISUISSE®

Rückzugsstahlhalter FE für Außengewinde Thread-cutting device FE for external thread

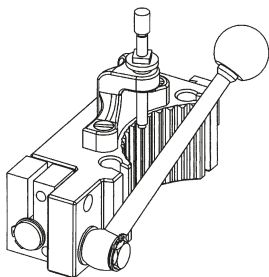

Vorgang: Mit dem Rückzugshebel kann ohne Verstellung des Kreuzsupports aus dem Gewinde ausgefahren werden. Es muß lediglich die neue Spantiefe nachgestellt werden.

Operation: The cutting blade can be retracted from the thread through the handle without moving the cross slide. The next cutting depth can be prepared during the tool's way back.

Typ / Type	Für Kopf / For turret	Hub / Stroke mm	Ø mm	Art.-Nr. / Order no.
AFE	A	11	12	▶ 50-100-115
EFE	E	12	12	▶ 50-100-133
BFE	B	10	20	▶ 50-100-150
CFE	C	14	20	▶ 50-100-168

Schnellwechselstahlhalter, ORIGINAL MULTISUISSE® Quick-change tool holders, ORIGINAL MULTISUISSE®

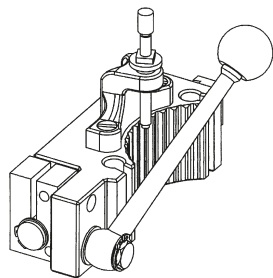

ORIGINAL MULTISUISSE®

Rückzugsstahlhalter FI für Innengewinde Thread-cutting device FI for internal thread

Vorgang: Mit dem Rückzugshebel kann ohne Verstellung des Kreuzsupports aus dem Gewinde ausgefahren werden. Es muß lediglich die neue Spantiefe nachgestellt werden.

Operation: The cutting blade can be retracted from the thread through the handle without moving the cross slide. The next cutting depth can be prepared during the tool's way back.

Typ / Type	Für Kopf / For turret	Hub / Stroke mm	Ø mm	Art.-Nr. / Order no.
AFI	A	11	12	▶ 50-100-116
EFI	E	12	12	▶ 50-100-134
BFI	B	10	20	▶ 50-100-151
CFI	C	14	20	▶ 50-100-169

Hülse mit Morsekegel L für Bohrstangenhalter J Bush with morse taper L for bush holder J

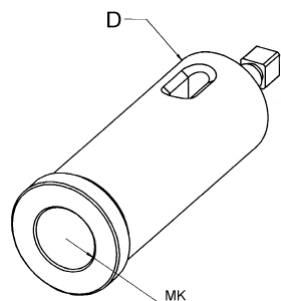

Typ / Type	MK / MT	D mm	Passend für / Matching to	Art.-Nr. / Order no.
AL	1	30	AJ 3080 / EJ 30100	● 50-100-119
AL	2	30	AJ 3080 / EJ 30100	● 50-100-120
BL	2	40	EJ 40100 / BJ 40120 / CJ 40160	● 50-100-135
BL	3	40	EJ 40100 / BJ 40120 / CJ 40160	● 50-100-136
BL	4	40	EJ 40100 / BJ 40120 / CJ 40160	● 50-100-137
CL	3	50	CJ 50160	● 50-100-171
CL	4	50	CJ 50160	● 50-100-172
CL	5	50	CJ 50160	● 50-100-173
DL	5	63	D1J 63180 / D2J 63220	● 50-100-183

ORIGINAL MULTISUISSE®

Einlegeprisma P für Bohrstahlhalter H Prism P for bar holder H

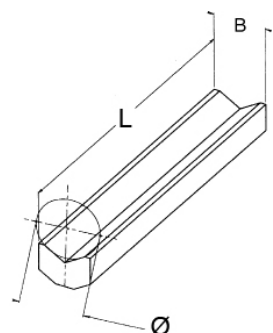

Typ / Type	Ø mm	L mm	B mm	Passend für / Matching to	Art.-Nr. / Order no.
AP	14	85	16	AH 2085	● 50-100-121
EP	16	100	20	EH 16100	● 50-100-138
BP	20	130	22	BH 32130	● 50-100-155
CP	25	160	30	CH 40160	● 50-100-174
CP	32	160	33	CH 50160	● 50-100-175
D1P	40	180	50	D1H 63180	● 50-100-184
D2P	45	220	60	D2H 70220	▶ 50-100-191

ORIGINAL MULTISUISSE®

Bohrstange M passend zu Halter J, ohne Drehling Boring bar M for bush holder J, without tool

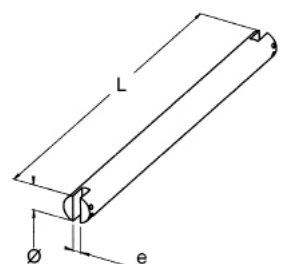







Typ / Type	Ø mm	L mm	e mm	Passend für / Matching to	Art.-Nr. / Order no.
AM	30	250	12	AJ 3080 / EJ 30100	▶ 50-100-122
BM	40	500	12	EJ 40100 / BJ 40120 / CJ 40160	▶ 50-100-140
CM	50	500	12	CJ 50160	▶ 50-100-176
D1M	63	600	12	D1J 63180 / D2J 63220	▶ 50-100-185



Schnellwechselstahlhalter, BASIC Quick-change tool holders, BASIC

















BASIC Kopf Turret



Größe / Size	Art.-Nr. / Order no.
Aa	 BAS-100-100
A	 BAS-100-106
E	 BAS-100-123
B	 BAS-100-141
C	 BAS-100-156
D	 BAS-100-177







BASIC Drehstahlhalter D Tool holder D



Typ / Type	Für Kopf / For turret	H mm	B mm	Art.-Nr. / Order no.
DAa	Aa	12	50	 BAS-100-101
DA	A	20	90	 BAS-100-110
DE	E	20	100	 BAS-100-125
DE	E	25	100	 BAS-100-126
DB	B	25	120	 BAS-100-142
DB	B	25	140	 BAS-100-143
DB	B	32	120	 BAS-100-144
DB	B	32	140	 BAS-100-145
DC	C	32	150	 BAS-100-157
DC	C	32	170	 BAS-100-158
DC	C	40	150	 BAS-100-159
DC	C	40	170	 BAS-100-160
DC	C	45	170	 BAS-100-161
DD	D	40	180	 BAS-100-178
DD	D	50	180	 BAS-100-179
DD	D	63	180	 BAS-100-180

BASIC Bohrstahlhalter H Bar holder H



Typ / Type	Für Kopf / For turret	H mm	B mm	Art.-Nr. / Order no.
HAa	Aa	12	50	 BAS-100-102
HA	A	20	90	 BAS-100-111
HE	E	30	100	 BAS-100-127
HB	B	32	130	 BAS-100-146
HC	C	32	160	 BAS-100-162
HC	C	40	160	 BAS-100-163
HD	D	50	180	 BAS-100-181



Schnellwechselstahlhalter, BASIC Quick-change tool holders, BASIC



BASIC

Bohrstangenhalter J Boring bar holder J

Typ / Type	Für Kopf / For turret	Ø mm	B mm	Art.-Nr. / Order no.
JAa	Aa	15	50	● BAS-100-103
JA	A	30	80	● BAS-100-112
JE	E	30	100	● BAS-100-129
JE	E	40	100	● BAS-100-130
JB	B	40	120	● BAS-100-147
JC	C	40	150	● BAS-100-164
JC	C	50	150	● BAS-100-165
JD	D	63	180	● BAS-100-182

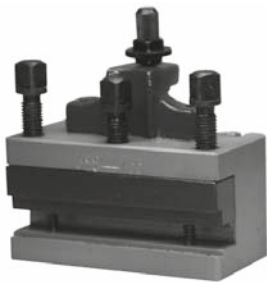

BASIC

Abstechhalter T Cutting-off holder T

Typ / Type	Für Kopf / For turret	Stahlgröße / Cutting tool size mm	Art.-Nr. / Order no.
TAa	Aa	2,7 x 10	● BAS-100-104
TA	A	2,7 x 10	● BAS-100-113
TE	E	2,7 x 10	● BAS-100-131
TB	B	4 x 16	● BAS-100-148
TC	C	5 x 18,5	● BAS-100-166

MK-Hülsen, Einlegeprismen und Bohrstangen siehe Seite 209. Ersatzteile auf Anfrage
For MT-sleeves, prism inserts and boring bars refer to page 209. Spare parts upon request



BASIC

Schnellwechselstahlhalter-Sätze Quick-change tool holder sets



Satz bestehend aus / Set consisting of

Größe / Size	Kopf / Turret	Drehstahlhalter / Tool holder	Bohrstahlhalter / Bar holder	Art.-Nr. / Order no.
Aa	1 x BAS-100-100	3 x BAS-100-101	1 x BAS-100-102	● BAS-SATZ-AA
A	1 x BAS-100-106	3 x BAS-100-110	1 x BAS-100-111	● BAS-SATZ-A
E	1 x BAS-100-123	3 x BAS-100-125	1 x BAS-100-127	● BAS-SATZ-E
B	1 x BAS-100-141	3 x BAS-100-142	1 x BAS-100-146	● BAS-SATZ-B
C	1 x BAS-100-156	3 x BAS-100-157	1 x BAS-100-163	● BAS-SATZ-C



Ersatzteile für Schnellwechselstahlhalter

Spare parts for quick-change tool holders

Exzentrerschlüssel

Lever



Für Kopf / For turret	Art.-Nr. / Order no.
Aa	▶ 50-100-221
A	▶ 50-100-222
E	● 50-100-223
B	● 50-100-223
C	▶ 50-100-225
D1	▶ 50-100-226
D2	▶ 50-100-227

Vierkantschraube

Square head screw



Für Kopf / For turret	Art.-Nr. / Order no.
Aa	▶ 50-100-249
A	● 50-100-250
E	● 50-100-250
B	● 50-100-251
C	● 50-100-252
D1	● 50-100-252
D2	▶ 50-100-253

Ringfeder

Spring



Für Kopf / For turret	Art.-Nr. / Order no.
A	▶ 50-100-301
E	▶ 50-100-301
B	● 50-100-303
C	● 50-100-304
D1	▶ 50-100-305
D2	▶ 50-100-306

Höhenverstellerschraube

Height adjusting screw



Für Kopf / For turret	Art.-Nr. / Order no.
Aa	▶ 50-100-254
A	● 50-100-255
E	● 50-100-370
B	● 50-100-256
C	● 50-100-257
D1	▶ 50-100-258
D2	▶ 50-100-258

Höhenverstellmutter

Stop nut



Für Kopf / For turret	Art.-Nr. / Order no.
Aa	▶ 50-100-259
A	● 50-100-260
E	● 50-100-260
B	● 50-100-261
C	● 50-100-262
D1	▶ 50-100-263
D2	▶ 50-100-263

Zeiger

Guard ring



Für Kopf / For turret	Art.-Nr. / Order no.
A	▶ 50-100-294
E	▶ 50-100-294
B	▶ 50-100-296
C	▶ 50-100-297
D1	▶ 50-100-298
D2	▶ 50-100-299

Konsole mit Schrauben und Mutter

Bracket with screws



Für Kopf / For turret	Art.-Nr. / Order no.
Aa	▶ 50-100-242
A	▶ 50-100-243
E	▶ 50-100-244
B	● 50-100-245
C	▶ 50-100-246
D1	▶ 50-100-247
D2	▶ 50-100-248

Vierkantsteckschlüssel

Socket wrench



Für Kopf / For turret	Art.-Nr. / Order no.
Aa	▶ 50-100-228
A	● 50-100-229
E	● 50-100-229
B	● 50-100-231
C	▶ 50-100-232
D1	▶ 50-100-232
D2	▶ 50-100-234

Spannband mit Exzenterbolzen

Clamping strap with eccentric bolt



Für Kopf / For turret	Art.-Nr. / Order no.
Aa	▶ 50-100-264
A	▶ 50-100-265
E	▶ 50-100-266
B	▶ 50-100-267
C	▶ 50-100-268
D1	▶ 50-100-269
D2	▶ 50-100-270

Schleifbandhalter Sanding belt holders

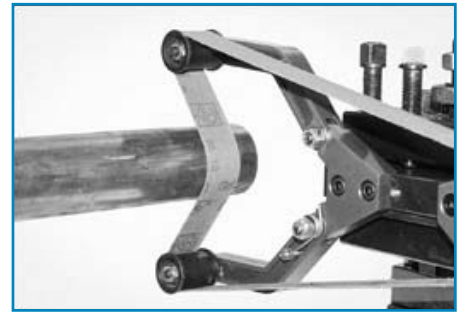

Schleifbandhalter, manuell Sanding belt holders, manually

- zum Einspannen in Drehstahlhalter
- Betätigung mittels Handkurbel
- zum Schleifen und Entgraten von Werkstücken
- for use in quick-change tool holders
- operated by hand crank
- used for the sanding and deburring of workpieces

Größe / Size	Ø Max. mm	Art.-Nr. / Order no.
1	155	ZE-SBH-100
2	210	ZE-SBH-200
4	423	ZE-SBH-400



Schleifbandhalter, automatisch Sanding belt holders, automatically

- zum Einspannen in Drehstahlhaltern
- mit automatischem Schiebesystem
- zum Schleifen und Entgraten von Werkstücken
- for use in quick-change tool holders
- with automatic sliding system
- used for the sanding and deburring of workpieces

Größe / Size	Ø Max. mm	Art.-Nr. / Order no.
1	155	ZE-ABH-100
2	210	ZE-ABH-200

Schleifbänder Sanding belts



Passend zu Größe / Fitting to size	Breite / Width mm	Länge / Length mm	Körnung / Grain	Art.-Nr. / Order no.
1	25	762	80	ZE-SBH-100/S80
1	25	762	100	ZE-SBH-100/S100
1	25	762	120	ZE-SBH-100/S120
1	25	762	180	ZE-SBH-100/S180
1	25	762	240	ZE-SBH-100/S240
1	25	762	320	ZE-SBH-100/S320
2	50	915	80	ZE-SBH-200/S80
2	50	915	100	ZE-SBH-200/S100
2	50	915	150	ZE-SBH-200/S150
2	50	915	180	ZE-SBH-200/S180
2	50	915	220	ZE-SBH-200/S220
2	50	915	320	ZE-SBH-200/S320
4	100	1372	80	ZE-SBH-400/S80
4	100	1372	120	ZE-SBH-400/S120
4	100	1372	150	ZE-SBH-400/S150
4	100	1372	220	ZE-SBH-400/S220
4	100	1372	320	ZE-SBH-400/S320



